



**7.2.1 Q1M Describe two best practices successfully implemented by the institution as per the NAAC format provided in the manual.**

Energy Efficiency (SDGs: 7/9/11/12/12/17):.....2

    Sensor-based energy conservation.....7

        Smart Lighting System-Patented Technology Transfer.....7

        Bills for the purchase of equipment’s for the facilities created under this metric.....23

        Outcome & Impact.....41

Use of LED bulbs/ power efficient equipment.....43

    Geo-tagged photographs.....43

    Bills for Purchase of equipment’s.....45

    Outcome & Impact.....97

**Registrar  
Atmiya University  
Rajkot**





**ENERGY EFFICIENCY (SDGS: 7/9/11/12/12/17):**

- Energy-efficient devices and smart systems optimize power usage, maintaining a near-perfect power factor.
- Well-ventilated, naturally lit, Eco-friendly building structure maximize natural light and ventilation, reducing artificial lighting and cooling needs.
- Saved **50 to 70%** on Energy by minimizing the need of Artificial Lighting, Fans and ACs in the day time and due to smart systems.



## Green Architecture

- Low artificial lighting requirements
- Energy consumption optimization
- Low green house gas emission
- Low level of strain to Eyes



**Registrar  
Atmiya University  
Rajkot**





**ATMIYA  
UNIVERSITY**

NAAC – Cycle – 1  
AISHE: U-0967

Criterion- VII

IV&BP

KI 7.2

M 7.2.1



  
**Registrar  
Atmiya University  
Rajkot**







**ATMIYA  
UNIVERSITY**

**NAAC – Cycle – 1  
AISHE: U-0967**

**Criterion- VII**

**IV&BP**

**KI 7.2**

**M 7.2.1**



**Registrar  
Atmiya University  
Rajkot**







**ATMIYA  
UNIVERSITY**

NAAC – Cycle – 1  
AISHE: U-0967

Criterion- VII

IV&BP

KI 7.2

M 7.2.1



**Registrar  
Atmiya University  
Rajkot**







**ATMIYA  
UNIVERSITY**

NAAC – Cycle – 1  
AISHE: U-0967

Criterion- VII

IV&BP

KI 7.2

M 7.2.1



  
**Registrar  
Atmiya University  
Rajkot**





**SENSOR-BASED ENERGY CONSERVATION**

**SMART LIGHTING SYSTEM-PATENTED TECHNOLOGY TRANSFER**

(12) PATENT APPLICATION PUBLICATION

(21) Application No.202421045036 A

(19) INDIA

(22) Date of filing of Application :11/06/2024

(43) Publication Date : 19/07/2024

(54) Title of the invention : SMART LIGHTING SYSTEMS FOR ENERGY CONSERVATION

(51) International classification :H05B0047110000, F21V0023040000, H04N0005330000, H05B0047100000, F21S0002000000

(86) International Application No :NA

Filing Date :NA

(87) International Publication No : NA

(61) Patent of Addition to Application Number :NA

Filing Date :NA

(62) Divisional to Application Number :NA

Filing Date :NA

(71)Name of Applicant :

1)Atmiya University

Address of Applicant :Atmiya University, "Yogidham Gurukul", Kalawad Road, Rajkot – 360005, Gujarat, India Rajkot -----

2)Dr. Ashish M. Kothari

Name of Applicant : NA

Address of Applicant : NA

(72)Name of Inventor :

1)Dr. Ashish M. Kothari

Address of Applicant :Director-Research, Innovation & Translation, Atmiya University, "Yogidham Gurukul", Kalawad Road, Rajkot – 360005 Rajkot -----

(57) Abstract :

Abstract Smart Lighting Systems for Energy Conservation The present invention provides a smart lighting system designed to conserve energy by automatically adjusting illumination based on ambient light conditions and human occupancy. The system includes a Light Dependent Resistor (L) sensor to monitor ambient light levels and a Passive Infrared (P) sensor to detect human motion. An Arduino UNO microcontroller (M) processes the input from these sensors to control a switching module (SM), which activates the lighting only when necessary. The system allows for customizable settings, enabling users to adjust the ambient light threshold and the duration for which the lights remain on after motion detection. This smart lighting system significantly reduces energy wastage, lowers electricity bills, and contributes to environmental sustainability. It is versatile and applicable in various indoor and outdoor environments, such as staircases, parking areas, building lobbies, halls, porches, decks, and backyards. Figure 1

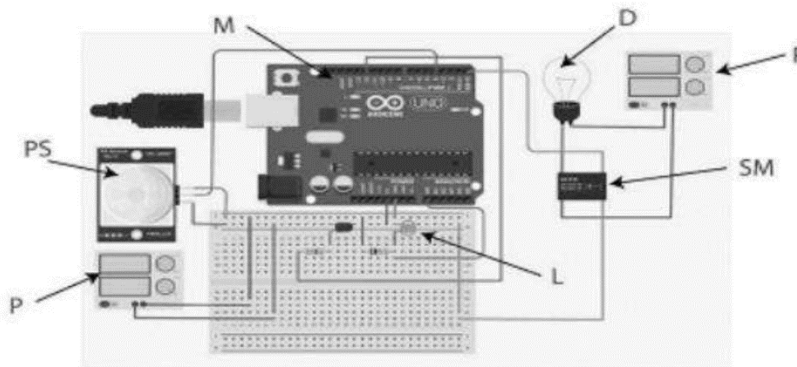
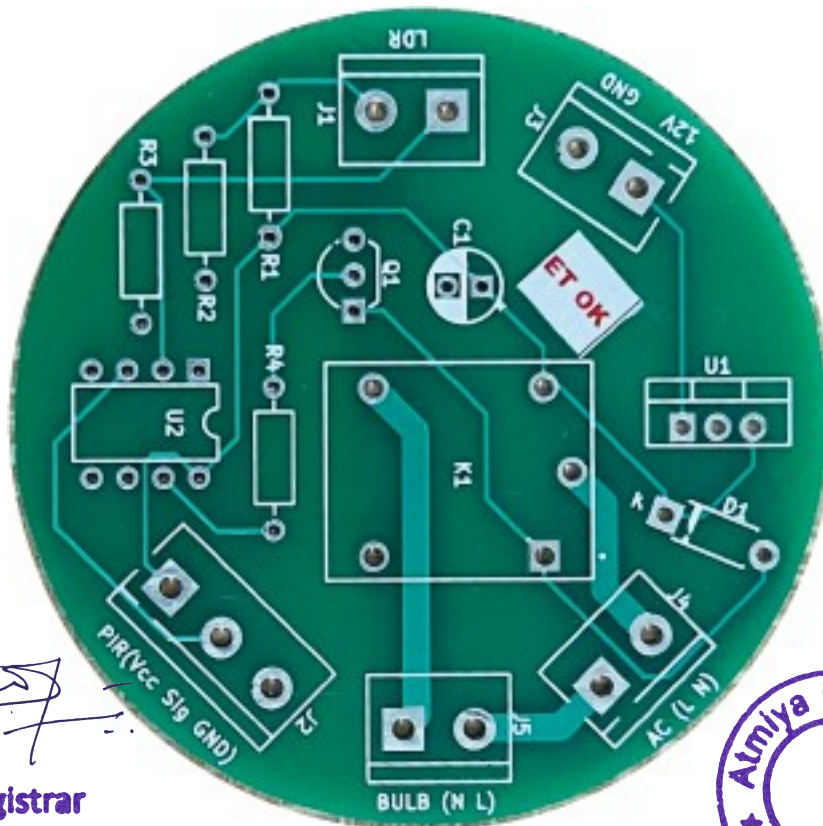
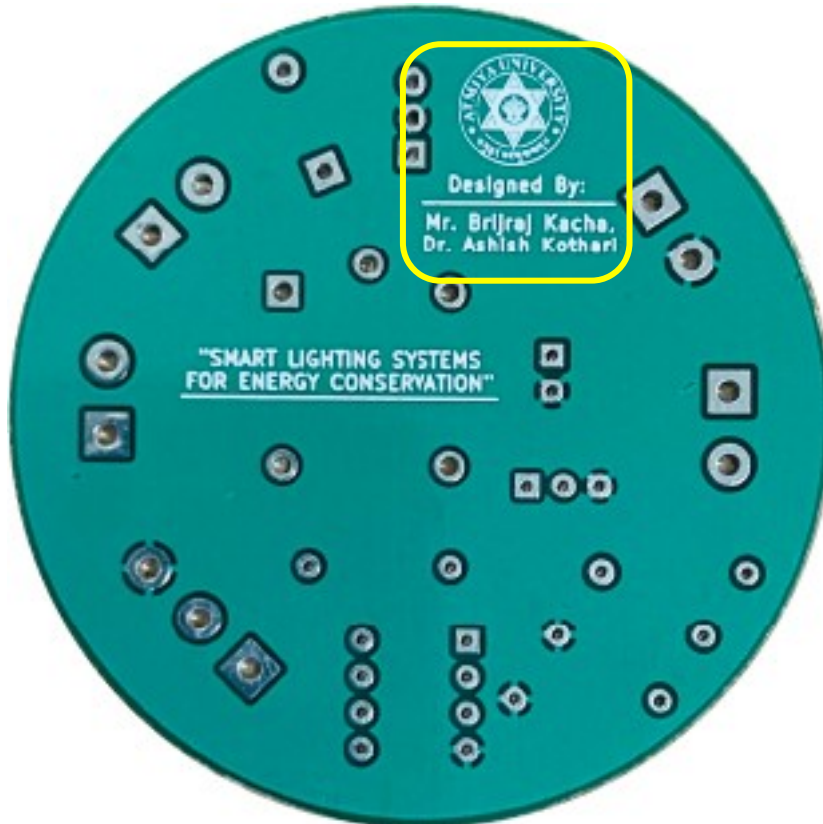

Figure 1 shows diagram of smart lighting system

**Registrar  
Atmiya University  
Rajkot**







**Registrar  
Atmiya University  
Rajkot**



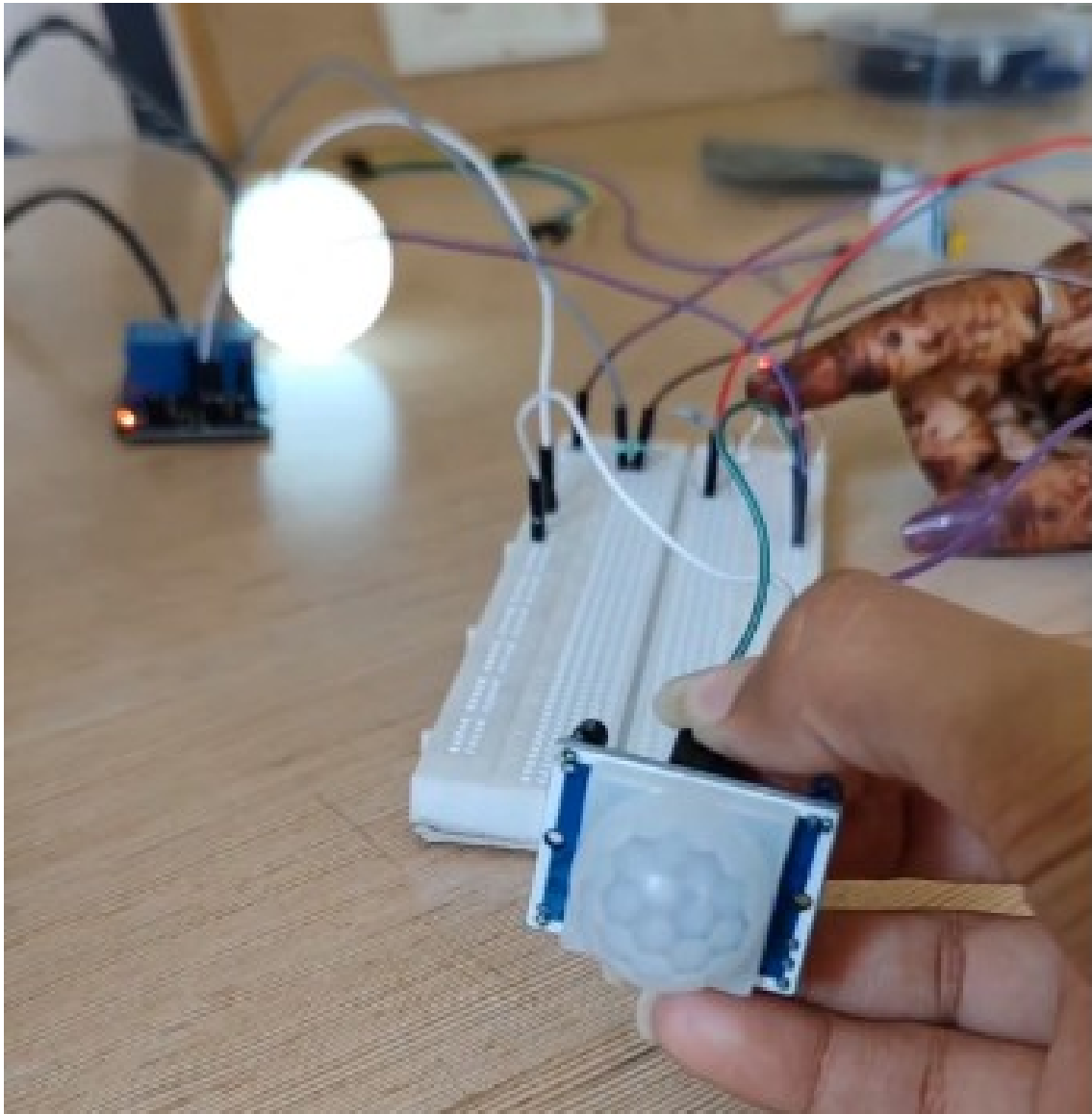

This invention presents a system aimed at energy conservation by activating lights only when necessary, thereby contributing to energy savings and mitigating global warming. The system utilizes a Light Dependent Resistor (LDR) sensor for monitoring ambient light intensity and a Passive Infrared (PIR) sensor for detecting human motion. An Arduino UNO microcontroller acts as the central processing unit, integrating inputs from both sensors to determine the appropriate timing for activating the switching module and illuminating the lights. Additionally, the system features an adjustable predefined time period during which the lights remain on after motion detection. Continuously operational as long as power is supplied, the system offers efficient lighting control based on ambient conditions and human presence, facilitating significant energy conservation efforts.

**Registrar  
Atmiya University  
Rajkot**

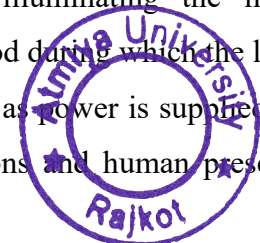



- Sensor based Air-conditioning Units



**Registrar  
Atmiya University  
Rajkot**







- Sensor based elevator system (SCADA)



**Registrar  
Atmiya University  
Rajkot**





**ATMIYA  
UNIVERSITY**

**NAAC – Cycle – 1  
AISHE: U-0967**

**Criterion- VII**

**IV&BP**

**KI 7.2**

**M 7.2.1**

- Sensor based air handling units



- Sensor based water pumping system

**Registrar  
Atmiya University  
Rajkot**



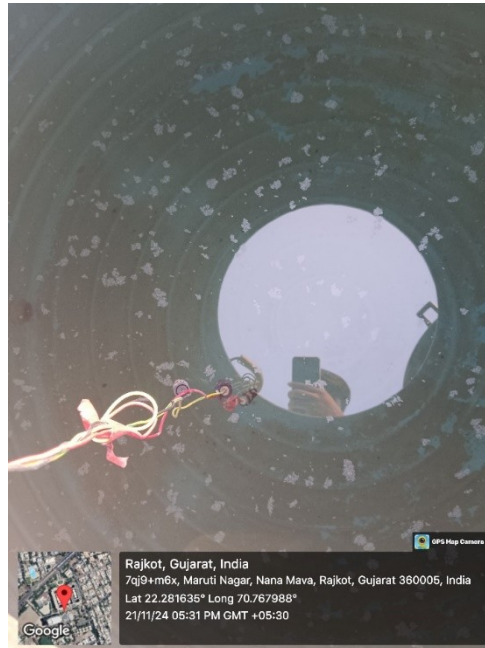

- Automatic mist system (Energy conservation) at *NIRAMAYA*: Advanced farming technology.

**Registrar  
Atmiya University  
Rajkot**







**Registrar  
Atmiya University  
Rajkot**





**Atmiya University, Rajkot, Gujarat India**

Latitude: 22; 16; 52.2780000000056333  
Longitude: 70; 45; 57.432000000000869  
Altitude: 103.2

23-05-2024

**Registrar  
Atmiya University  
Rajkot**







- Received Financial Rebates of **Rs. 5,78,019** from **PGVCL** for excellent power factor.

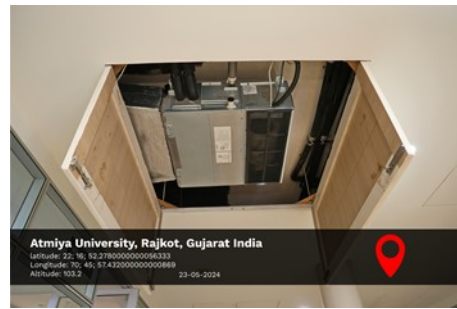

**Registrar**  
**Atmiya University**  
**Rajkot**





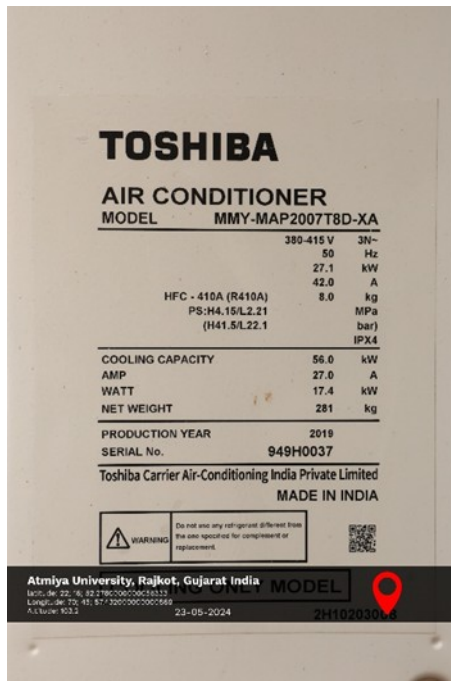

**Registrar  
Atmiya University  
Rajkot**





Sensor based energy saver air conditioning units for Auditoriums



**Registrar  
Atmiya University  
Rajkot**







Motion sensor camera systems for energy and data conservation

Motion & IR Sensor based energy saver camera



**Registrar  
Atmiya University  
Rajkot**







Smart, sensor based gym equipment for energy conservation



**Registrar  
Atmiya University  
Rajkot**





Sensor based cold storage for energy conservation



**Registrar  
Atmiya University  
Rajkot**





**Smart sensor based power backup system**



**Registrar  
Atmiya University  
Rajkot**







**Smart Photocopier Machine for Energy Conservation**



**Registrar  
Atmiya University  
Rajkot**





**ATMIYA  
UNIVERSITY**

**NAAC – Cycle – 1  
AISHE: U-0967**

**Criterion- VII**

**IV&BP**

**KI 7.2**

**M 7.2.1**

**BILLS FOR THE PURCHASE OF EQUIPMENT'S FOR THE FACILITIES  
CREATED UNDER THIS METRIC.**

Sensor-based lighting

**Tax Invoice** (ORIGINAL FOR RECIPIENT)

<b>CHANDAN ELECTRIC SERVICE</b> "Sneh Ashish" New Jagnath, Rajkot - 360001 Contact : 9909905526/9429501677 E-Mail : chandaneleservice@yahoo.com GSTIN/UIN: 24ABJPC0071B1ZJ State Name : Gujarat, Code : 24		Invoice No. <b>CES/164/24-25</b>	Dated <b>9-Apr-24</b>
Buyer (Bill to) <b>Atmiya University - FOS</b> Faculty of Science Rajkot State Name : Gujarat, Code : 24		Delivery Note <b>4793, 4944</b>	Other References
		Reference No. & Date.	
		Buyer's Order No.	Dated
		Dispatch Doc No.	Delivery Note Date <b>23-Jan-24, 31-Jan-24</b>
		Dispatched through	Destination

Sl No.	Description of Goods	HSN/SAC	Quantity	Rate	per	Disc. %	Amount
1	Order No:- 4793 Date 23-1-2024 <b>Halonix Sensor LED Lamp 10W</b> Motion Sensor	85395200	15 Nos	220.00	Nos		3,300.00
2	Order No:- 4944 Date 31-1-2024 <b>PVC Connector</b>	39269099	20 Nos	15.00	Nos		300.00
							3,600.00
							C Gst
							S Gst
							Round Off
							324.00
							324.00
<b>Total</b>			<b>35 Nos</b>				<b>₹ 4,248.00</b>

**PAID**

AxIS Poo h 98 94503.

Bank **AXIS**

Date **10/5/24**

Prev Balance	
Bill Amount	<b>4,248.00 Dr</b>
Net Balance	<b>4,248.00 Dr</b>

Amount Chargeable (in words)

**INR Four Thousand Two Hundred Forty Eight Only**

Taxable Value	CGST Rate	CGST Amount	SGST/UTGST Rate	SGST/UTGST Amount	Total Tax Amount
3,600.00	9%	324.00	9%	324.00	648.00
<b>Total:</b>		<b>324.00</b>		<b>324.00</b>	<b>648.00</b>

Tax Amount (in words) : **INR Six Hundred Forty Eight Only**

Company's Bank Details	
Bank Name	<b>Hdfc Bank</b>
A/c No.	<b>50200123000000000000</b>
Branch & IFS Code	<b>Dr.Yagnik Road &amp; IFS Code: RAJKO03</b>

Declaration  
We declare that this invoice shows the actual price of the goods described and that all particulars are true and correct.

Authorized Signatory

This is a Computer Generated Invoice

**Registrar  
Atmiya University  
Rajkot**







## Sensor based energy efficient lift system



॥ SWAMI SHREEJI ॥

### SARVODAY KELAVANI SAMAJ

Trust Registration. No. F - 28, (RAJKOT)

"YOGIDHAM GURUKUL", KALAWAD ROAD, RAJKOT - 360 005

● PRESIDENT : H.D.H. P.P. HARIPRASAD SWAMIJIMAHARAJ  
● SECRETARY : SADHU TYAGVALLABHDASJI

Ph. : +91 - 281 - 2563555 | Fax : +91 - 281 - 2563952  
E-mail : yogidhamrajkot@yahoo.com | Website : www.sks.ac.in

#### PURCHASE/WORK ORDER

No. SKS/Passenger Elevator/PO/092021-22  
Date: 17-06-2021

To,  
The Managing Director,  
M/s. Toshiba Johnson Elevators India Pvt Ltd,  
602, 6th Floor, C&B Square,  
Sangam Complex, 127, Andheri Kurla Road,  
Andheri (E), Mumbai - 400 059.

Sub : Design, Supply, Installation, Testing and commissioning of 11 nos. of Toshiba Make ELCOSMO-III Elevators Auto Door Machine Room Elevator.

REF: - Your Revised Quotation no. LIFT/TSB/IE-4054 Dated: 10-03-2021.

Dear Sir,

With reference to your quotation LIFT/TSB/IE-4054 Dated: 10-03-2021 and our negotiation with you, We are pleased to place an order for supply & erection work of 11 nos. of Toshiba Make ELCOSMO-III Auto Door Machine Room fully imported Elevators as per price and detail specification enclosed in Annexure-I, II and III with following Terms and Conditions.

#### Annexure - I

Sr. No.	Description	Qty.	SITC Unit Price In ₹ (Rs.)	SITC Total Amount in ₹ (Rs.)
1	<b>Elevators Name : ELCOSMO-III (P1-P4)</b> P29(1972)-CO - 105MPM -13/13 S/O- MR Speed: 1.75 mps, No of Stop/Opening:13, Center Opening, Car Size: 2000 (W) x 2050 (D)x2300 (H)MM, Car Door Size: 1100MM(W)x 2100MM (H), ARD, Touchless system in car operating panel and hall indicator panel, EMS system <b>Detail Specification Mention In Annexure -II</b>	4	29,55,239=00	1,18,20,956=00
2	<b>Elevators Name : ELCOSMO-III (P5-P8)</b> P15(1020)-CO -105MPM -12/12 S/O- MR Speed: 1.75 mps, No of Stop/Opening:12, Center Opening, Car Size : 1800(W) x 1350(D)x2300 (H)MM, Car Door Size : 1000MM(W)x 2100MM (H), ARD, Touchless system in car operating panel and hall Indicator panel, EMS system <b>Detail Specification Mention In Annexure -II</b>	4	17,65,942=00	70,63,768=00

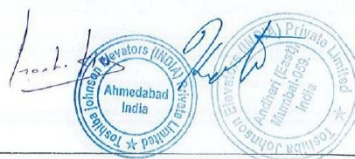

Page 1 of 14

● Atmiya University ●  
● Atmiya Institute of Technology & Science for Diploma Studies ● Shree Manibhai Virani & Smt. Navalben Virani Science College ●  
● Shree Atmiya Shishu Vidya Mandir ● Shree Sarveshwar Vidya Mandir ●

Registrar  
Atmiya University  
Rajkot





II SWAMI SHREEJI II

## SARVODAY KELAVANI SAMAJ

Trust Registration. No. F - 28, (RAJKOT)

"YOGIDHAM GURUKUL", KALAWAD ROAD, RAJKOT - 360 005

● PRESIDENT : H.D.H. P.P. HARIPRASAD SWAMIJIMAHARAJ  
● SECRETARY : SADHU TYAGVALLABHDASJI

Ph. : +91 - 281 - 2563555 | Fax : +91 - 281 - 2563952  
E-mail : yogidhamrajkot@yahoo.com | Website : www.sks.ac.in

3	<b>Elevators Name : ELCOSMO-III (P9-P10)</b> P9(612)-2S-105 MPM -12/12 S/O- MR Speed: 1.75 mps, No of Stop/Opening:12, Two Side Telescopic. Opening ,Car Size : 1200(W) x 1100(D)x2300(H) MM, Car Door Size : 800MM(W)x 2100MM (H), ARD, Touchless system in car operating panel and hall indicator panel, EMS system <b>Detail Specification Mention In Annexure -II</b>	2	19,61,895=00	39,23,790=00
4	<b>Elevators Name : EL.COSMO-III (P11)</b> P9(612)-CO - 105MPM -7/7 S/O- MR Speed: 1.75 mps, No of Stop/Opening:7, Center Opening ,Car Size : 1300(W) x 1200(D)x 2300 (H)MM, Car Door Size : 800MM(W)x 2100MM (H), ARD, Touchless system in car operating panel and hall indicator panel, EMS system <b>Detail Specification Mention In Annexure -II</b>	1	13,44,028=00	13,44,028=00
			<b>Total Basic Amount</b>	<b>2,41,52,542=00</b>
			<b>GST@18%</b>	<b>43,47,458=00</b>
			<b>Packing Charges</b>	<b>Inclusive</b>
			<b>Installation Charges</b>	<b>Inclusive</b>
			<b>Transportation/Insurance/Shifting/unloading material Charges</b>	<b>Inclusive</b>
			<b>TOTAL Amount in ₹ Rs.</b>	<b>2,85,00,000=00</b>
<b>Total Amount Rupees Two Crore Eighty Five lacks Rupees only.</b>				
<b>Note: SITC: Supply, Installation, Testing, COMMISSIONING, CO: Door Arrangement Center Opening, P: Passengers, 2S: Two Side Telescopic Door Opening (Front and Rear)</b>				

**Terms & Conditions:**

- The prices quoted above (mention in Annexure-1) are F.O.R. site inclusive of design, Packing, Forwarding, Freight, insurance, loading, unloading, shifting and labor for erection/fabrication/installation as per approved plan, design & drawing, commissioning, GST and all types of taxes and duties as applicable by respective any government body at the time of supply & execution of work.
- If any additional liability on account of regarding any kind of taxes and duties except GST arises at a future date that shall be borne by you.
- The order to be placed on you shall be as per the terms & conditions laid down in our purchase order and not as per either you Quotation/Sales order or your company product manufactures terms & conditions.
- CAMC Means Comprehensives Annual Maintenance Contract.
- TJEL/Company/Contractor means Toshiba Johnson Elevators India Pvt. Ltd. Mumbai
- Client/Institute means: Sarvodaya Kelavani Samaj, Rajkot
- Project completion means its covered completion timeline of delivery, installation and Commissioning.
- Country of OEM : Japan

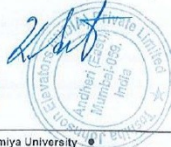
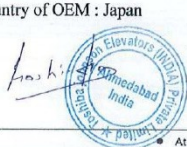

**Registrar  
Atmiya University  
Rajkot**







II SWAMI SHREEJI II

## SARVODAY KELAVANI SAMAJ

Trust Registration No. F - 28, (RAJKOT)

"YOGIDHAM GURUKUL", KALAWAD ROAD, RAJKOT - 360 005

● PRESIDENT : H.D.H. P.P. HARIPRASAD SWAMIJIMAHARAJ  
● SECRETARY : SADHU TYAGVALLABHDASJI

Ph. : +91 - 281 - 2563555 | Fax : +91 - 281 - 2563952

E-mail : yog.dhamrajkot@yahoo.com | Website : www.sks.ac.in

9. Manufacturing Country of Material: China
10. The materials specification (Detail configuration) mentioned in Annexure-I, II & III.
11. Elevators monitoring and touch less system detail mentioned in Annexure -III.
12. **Scope of work** : Planning, Designing, Engineering, Manufacturing, Supplying, Fabrication, Installation and Commissioning work along with 2 years of Free Maintenance of **11 nos. of Toshiba Make ELCOSMO-III Auto Door Machine Room fully imported Elevators** as per present standard specification and designs as per approved drawings which follows NBC / ISI / GUJRAT LIFT ACT include all required elevators related materials and accessories complete on Turnkey basis.
13. All the materials/products shown in Annexure-I, II & III as per approved plan, drawing & specification must be delivered at the Institute without any damage or it should be in company seal container. If anyone of this are found damage or broken condition at the time of unloading at site, it must be replaced at your own risk & cost.
14. If any kind of specified or unspecified materials are required related to erection of above Elevators at site, you must have to provide without taking any extra charges.
15. Terms of Payment:
  - (i) 10% of total PO value shall be payable as advance against Performa Invoice and signing of Purchase order.
  - (ii) Phase II: - 60% of PO value on pro-rata basis shall be paid (as mention in Annexure-I) through an irrevocable Letter of Credit at sight in Indian Rupees based on UCPDC terms satisfactory to us, negotiable against presentation of delivery documents.
    - a) 25% shall be payable against document of receiving all elevators guide rail and Entrance material at site.
    - b) 35% shall be payable against document receiving all other all elevator material at site.
    - c) The Letter of Credit shall be opened within one (1) month from the date of acceptance of this purchase order and shall be valid till 60 days from the date of last shipment.
    - d) All banking charges for L/C opening, the L/C amendment fee and confirmation charges shall be borne by Institute.
  - (iii) Phase-III: - 10% of total PO value after satisfactory completion of fabrication, installation and preliminary operation (in slow speed) of all elevators at our site as per approved plan/drawing & criteria.
  - (iv) Phase-IV: - 15% of total PO value after satisfactory completion of testing, QC with start high speed of all elevators at our site as per approved plan/drawing & criteria, commissioning, Elevator licenses and handed over all elevators without any pending issue.



Page 3 of 14

● Atmiya Institute of Technology & Science for Diploma Studies ● Shree Manibhai Virani & Smt. Navabai Virani Science College ●  
● Shree Atmiya Shishu Vidyanandir ● Shree Sarveshwer Vidyanandir ●

**Registrar**  
**Atmiya University**  
**Rajkot**





॥ SWAMI SHREEJI ॥

## SARVODAY KELAVANI SAMAJ

Trust Registration No. F - 28, (RAJKOT)

"YOGIDHAM GURUKUL", KALAWAD ROAD, RAJKOT - 360 005

● PRESIDENT : H.D.H. P.P. HARIPRASAD SWAMIJIMAHARAJ  
● SECRETARY : SADHU TYAGVALLABHDASJI

Ph. : +91 - 261 - 2563555 | Fax : +91 - 261 - 2563952  
E-mail : yogidhamrajkot@yahoo.com | Website : www.sks.ac.in

27. Attested copy of "Pan Card" must be submitted with the bill. TDS will be deducted from the bill as per the govt. rule.
28. It is compulsory to depute one experienced technical Engineer for supervision of above work at the time of execution. You must be submitting Engineer detail like name, contact no. etc...
29. You should ensure that if any facilities or items required for implementation at the site, then it should be notified to institute two weeks before the date of fabrication.
30. Any damage our infrastructure is done by the employees working under the contractor or company, then the organization has right to deduct the loss amount form the company's bill.
31. We will provide lockable storage for elevators materials. You are responsible for lost or any type of damaged elevator materials from the store room during the installation period and you have to replace those materials without taking any cost. If any delay/stop of work at site more than 12 months by customer, then the responsibility to store material will be of customer.
32. All the labours involved in the work must be insured by you before commencement of work on our site.
33. We will not be responsible for any kind of Compensation in case of labour injury that occurs during working period at the site.
34. During erection/execution of above work, precaution must be taken to avoid any type of accidents. Otherwise TJEI is fully responsible for legal & financial liabilities of such accident.
35. TJEI will provide output to connect with third party BMS system which is installed by institute.
36. **Other Features:** Above system must be compatible to PC Monitoring/Third party BMS monitoring system (EMS Mention monitoring feature compatible with third party BMS) along with addition of extra system in future date subject to cost impact.
37. TJEI is bound to take all the responsibilities, if any type of design fault arises or any deviation/defect is noticed or if anyone/part of the fitting area which are found uneven or improper in above project and you must have to make necessary all arrangement for rectification, repairing etc. without taking any charges.
38. Below mention failure of Components /vandalism by your authorized person /engineer /contractor then it can be covered during free maintenance/CAMC period otherwise not covered.
  - a) Finished Stainless steel / Painted Panels, Face Plates, Cage panels, landing doors, Cabin Lighting, etc.
  - b) Failure of Components due to Vandalism, Water or Debris falling on the equipment.

Page 5 of 14

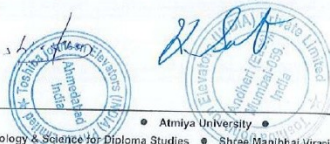

● Atmiya Institute of Technology & Science for Diploma Studies ● Shree Manibhai Virani & Smt. Navalben Virani Science College ●  
● Shree Atmiya Shishu Vidyamandir ● Shree Sarveshwar Vidyamandir ●

**Registrar**  
**Atmiya University**  
**Rajkot**







॥ SWAMI SHREEJI ॥

## SARVODAY KELAVANI SAMAJ

Trust Registration No. F - 28, (RAJKOT)

"YOGIDHAM GURUKUL", KALAWAD ROAD, RAJKOT - 360 005

● PRESIDENT : H.D.H. P.P. HARIPRASAD SWAMIJIMAHARAJ  
● SECRETARY : SADHU TYAGVALLABHDASJI

Ph. : +91 - 281 - 2563555 | Fax : +91 - 281 - 2563952  
E-mail : yogidhamrajkot@yahoo.com | Website : www.sks.ac.in

- e) Failure of Components due to improper ventilation, heat & humidity in the machine room.
- d) Failure of Components due to Lift being operated / Serviced by unauthorized person/ Agencies without prior / proper notice to us.
- e) Any damages due to Incidents / Accidents due to unsafe practices / use of elevators.
- f) Any damages due to Fire, Flood, Burglary, Natural Calamities.
- 39. 24 months on site full warrantee for (incl. Parts + Labour + Freight) Exchange in all type of components. It should cover repair / exchange of any parts that means institute will not pay any charges during warranty period for labour, parts, advance exchange and repairing or replacement of material and its accessories.
- 40. TJEI is bound to take all the responsibilities 18 months from the date of shipment under Defect Liability period, also you have to provide free Comprehensive maintenance period of 24 months after completion of defect liability period, during this period if any type of fault arises in above project and you must have to make necessary all arrangement for rectification, repairing etc. without taking any charges.
- 41. Response time for service should be less than 2 Hours on logging of every call for complain.
- 42. If any repairing/service is needed urgently during guarantee/free Comprehensive maintenance period, then you have to arrange your technician Engineer within 24 hrs after logging complain without taking any charges.
- 43. Any kind of parts/equipments of elevators and all other accessories etc. which will require replacing during warrantee/free comprehensive maintenance period, you have to supply immediately within 10 days to avoid any disturbance.
- 44. Any delay in attending breakdown, arrangement of spare parts during troubleshooting leads to delay of 10 days or more in operation of lift. It will count during negotiation of AMC contract.
- 45. You must be provided one service for every month during warranty / free maintenance period. But you must have to attend for every complain at any time in any case or in between month, any extra service required you must have to provide it without taking any extra charges.
- 46. Before starting the any kind of service, maintenance or repairing work, it is necessary to inform us or our representative and also compulsory to sign by your representative on institute complaint cum visit register.
- 47. It is compulsory to certified service report with all details by our authorized person for the work done by your service representative and also a copy of the same must be submitted to the institute for record purpose.

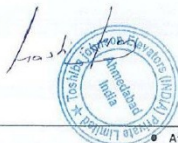

Page 6 of 14

Atmiya University  
● Atmiya Institute of Technology & Science for Diploma Studies ● Shree Manibhai Virani & Smt. Navaiaben Virani Science College ●  
● Shree Atmiya Shishu Vidyamandir ● Shree Sarveshwar Vidyamandir ●

**Registrar**  
**Atmiya University**  
**Rajkot**





॥ SWAMI SHREEJI ॥

## SARVODAY KELAVANI SAMAJ

Trust Registration No. F - 28, (RAJKOT)

"YOGIDHAM GURUKUL", KALAWAD ROAD, RAJKOT - 360 005

● PRESIDENT : H.D.H. P.P. HARIPRASAD SWAMIJIMAHARAJ  
● SECRETARY : SADHU TYAGVALLABHDASJI

Ph. : +91 - 281 - 2563555 | Fax : +91 - 281 - 2563952  
E-mail : yogidhamrajkot@yahoo.com | Website : www.sks.ac.in

48. All relevant statutory approvals required for the installation and operation of the elevators shall be coordinated by TJEI, Payment of inspection fees and any other incidental / monetary expenses will be in client scope.
49. CAMC Price: After 24 months Free maintenance period 3.25% CAMC Value on total basic value of 11 nos. of Toshiba make Elevators and 5% of escalation on CAMC value year on year.
50. Literature / Illustration pamphlets / Instruction manual for the machines under the acceptance must be send along with to the stores.
51. It is mandatory to mention Purchase Order No & Date, challan No & Date in each bill & other document related to purchase order otherwise bill will not be process for payment and we will not be responsible for the any delay of payment.
52. you are requested to confirm the receipt of purchase order duly signed by you and the same must be sent by post/scanned copy by e-mail within a week from the date of purchase order if the material / good supplied by you without confirmation that means you have accepted P.O with terms and condition started therein.
53. The bill should be submitted in triplicate.
54. Billing & Shipping Address: Sarvoday Kelavani Samaj, "Yoghdam Gurukul" Atmiya campus, Kalawad Road, RAJKOT-360005 (GUJARAT-INDIA).
55. All the issues and claims are subject to Rajkot jurisdiction

Thanking you,

  
Dr. Samir K Vaidya,  
SECRETARY,  
SARVODAY KELAVANI SAMAJ,  
RAJKOT.  
Enel: Annexure – II & III.



ok  

**Accepted by**

Sign : Mr. Katsuki  
Name :  
Designation :  
Date : 14/07/2021  
Stamp :



Page 7 of 14

  
**Registrar**  
**Atmiya University**  
**Rajkot**







|| SWAMI SHREEJI ||

## SARVODAY KELAVANI SAMAJ

Trust Registration No. F-28, (RAJKOT)

"YOGIDHAM GURUKUL", KALAWAD ROAD, RAJKOT - 360 005

● PRESIDENT : D.D.H. P.R. PARIPRASAD SWAMIJIMAHARAJ  
● SECRETARY : SADHU TYAGVALLABHDASJI

Ph. +91 - 281 - 2563555 | Fax : +91 - 281 - 2563952  
E-mail : yojidham\_rajkot@yahoo.com | Website : www.sks.ac.in

### Annexure – II

#### Technical specifications for Toshiba Make ELCOSMO-III Auto Door Machine Room Lift

Sl. No.	Elevators Description	Elevators Name :	Elevators Name :
		ELCOSMO-III (P1-P3)	ELCOSMO-III (P4-P5)
1	MODEL NO.	P29(1972)-105MPM 13/13 - S/O - CO -MR	P15(1020)-105MPM 12/12 -S/O - CO MR
2	QUANTITY/USAGE	4/PASSENGER	4/PASSENGER
3	CAPACITY IN KGS	1972	1020
4	NO. OF PERSON /CABIN TYPE	29/WIDER CABIN	15/ WIDER CABIN
5	SPEED /CONTROL	1.75 mps /VVVF	1.75 mps /VVVF
6	MOTOR CAPACITY (KW)	SHALL BE SUBMITTED DURING GAD SUBMISSION	
7	OPERATION	DUPLEX COLLECTIVE OPERATION WITH EMS	
8	NO. OF STOP/OPENING	13	12
9	FLOOR DESIGNATION	B2,B1,G,1-10	B2,B1,G,1-9
10	TRAVEL IN METERS	AS PPER BUILDING DRAWINGS / SITE CONDITION	
11	HOIST WAY SIZE AVAILABLE/REQUIRED (W*D)	2600*3000 MM	2400*2000 MM
12	PIT DEPTH AVAILABE/REQUIRED(MM)	1450 MM	1450 MM
13	OVERHEAD HEIGHT AVAILABLE/REQUIRED (MM)	AS PER SITE	AS PER SITE
14	LOCATION OF MACHINE	ABOVE THE HOISTWAY	ABOVE THE HOISTWAY
15	DOOR OPENING ARRAGEMENT	CENTRE OPENING	CENTRE OPENING
16	CAR INTERNAL SIZE (W*DXH)	2000 X 2050 X 2300MM	1800 X 1350 X 2300 MM
17	CAR DOOR WIDTH X HEIGHT (MM)	1100 X 2100 MM	1000 X 2100 MM
18	POWER SUPPLY	415V , 50HZ	415V , 50HZ
19	CABIN LIGHTING POWER SUPPLY	220V	220V
20	CABIN CEILING TYPE AND MATERIAL	SL - 1 IN STAINLESS STEEL HAIRLINE FINISH	
21	CABIN VENTILATION	2 NOS OF BLOWER PROVIDED	
22	CABIN FLOORING	IN CUSTOMER'S SCOPE	
23	CAR AND LANDING SILLS	ALUMINIUM	
24	ENTRANCE JAMBS TYPE & FINISH ON GR. AND OTHER FLOORS	NARROW JAMB IN SUS HL	NARROW JAMB IN SUS HL
25	LANDING DOORS ( FINISH ) ON GROUND AND ALL OTHER FLOOR	IN STAINLESS STEEL HAIRLINE FINISH	IN STAINLESS STEEL HAIRLINE FINISH
26	CABIN OPERATING PANEL TYPE	COP-GIK WITH DOT MATRIX INDICATOR	COP-GIK WITH DOT MATRIX INDICATOR
27	BUTTON TYPE FOR COP AND HALL INDICATOR	KB-7	KB-7
28	BUTTON COLOR	ORANGE	ORANGE
29	FACE PLATE FINISH FOR COP AND HALL INDICATOR	IN STAINLESS STEEL HAIRLINE FINISH	IN STAINLESS STEEL HAIRLINE FINISH
30	HALL INDICATOR TYPE ON GROUND AND ALL OTHER FLOOR	HIB-GIK	HIB-GIK
31	AUTOMATIC RESCUE DEVICE , EMERGENCY LANDING DEVICE	PROVIDED	PROVIDED

Page 8 of 14



*Handwritten signature*



Atmiya University  
● Atmiya Institute of Technology & Science, Rajkot  
● Shree Atmiya School, Rajkot  
● Shree Mahatma Gandhi Smt. Navabehn Virani Science College  
● Shree Sarveshwar Vidyamandir

*Handwritten signature*

**Registrar  
Atmiya University  
Rajkot**





II SWAMI SHREEJI II

## SARVODAY KELAVANI SAMAJ

Trust Registration No. F - 28, (RAJKOT)

“YOGIDHAM GURUKUL”, KALAWAD ROAD, RAJKOT - 360 005

● PRESIDENT : H.D.H. P.P. HARIPRASAD SWAMIJI MAHARAJ  
● SECRETARY : SADHU TYAGVALLABHDASJI

Ph. : +91 - 281 - 2563555 | Fax : +91 - 281 - 2563952

E-mail : yogidhamrajkot@yahoo.com | Website : www.sks.ac.in

### Annexure – II

#### Technical specifications for Toshiba Make ELCOSMO-III Auto Door Machine Room Lift

1	MODEL NO.	P29(1972)-105MPM 13/13 - S/O - CO -MR	P15(1020)-105MPM 12/12 -S/O - CO MR
2	QUANTITY/USAGE	4/PASSENGER	4/ PASSENGER
3	CAPACITY IN KGS	1972	1020
4	NO. OF PERSON /CABIN TYPE	29 /WIDER CABIN	15/ WIDER CABIN
5	SPEED /CONTROL	1.75 mps /VVVF	1.75 mps /VVVF
6	MOTOR CAPACITY (K W)	SHALL BE SUBMITTED DURING GAD SUBMISSION	
7	OPERATION	DUPEX COLLECTIVE OPERATION WITH EMS	
8	NO. OF STOP/OPENING	13	12
9	FLOOR DESIGNATION	B2,B1,G,1-10	B2,B1,G,1-9
10	TRAVEL IN METERS	AS PPER BUILDING DRAWINGS / SITE CONDITION	
11	HOIST WAY SIZE AVAILABLE/REAUURED (W*D)	2600*3000 MM	2400*2000 MM
12	PIT DEPTH A VAILABE/REQUIRED(MM)	1450 MM	1450 MM
13	OVERHEAD HEIGHT AVAILABLE/REQUIRED (MM)	AS PER SITE	AS PER SITE
14	LOCATION OF MACHINE	ABOVE THE HOISTWAY	ABOVE THE HOISTWAY
15	DOOR OPENING ARRAGEMENT	CENTRE OPENING	CENTRE OPENING
16	CAR INTERNAL SIZE (WXDXH)	2000 X 2050 X 2300MM	1800 X 1350 X 2300 MM
17	CAR DOOR WIDTH X HEIGHT (MM)	1100 X 2100 MM	1000 X 2100 MM
18	POWER SUPPLY	415V , 50HZ	415V , 50HZ
19	CABIN LIGHTING POWER SUPPLY	220V	220V
20	CABIN CEILING TYPE AND MATERIAL	SL - 1 IN STAINLESS STEEL HAIRLINE FINISH	
21	CABIN VENTILATION	2 NOS OF BLOWER PROVIDED	
22	CABIN FLOORING	IN CUSTOMER'S SCOPE	
23	CAR AND LANDING SILLS	ALUMINIUM	
24	ENTRANCE JAMBS TYPE & FINISH ON GR. AND OTHER FLOORS	NARROW JAMB IN SUS HL	NARROW JAMB IN SUS HL
25	LANDING DOORS ( FINISH ) ON GROUND AND ALL OTHER FLOOR	IN STAINLESS STEEL HAIRLINE FINISH	IN STAINLESS STEEL HAIRLINE FINISH
26	CABIN OPERATING PANEL TYPE	COP-G1K WITH DOT MATRIX INDICATOR	COP-G1K WITH DOT MATRIX INDICATOR
27	BUTTON TYPE FOR COP AND HALL INDICATOR	KB-7	KB-7
28	BUTTON COLOR	ORANGE	ORANGE
29	FACE PLATE FINISH FOR COP AND HALL INDICATOR	IN STAINLESS STEEL HAIRLINE FINISH	IN STAINLESS STEEL HAIRLINE FINISH
30	HALL INDICATOR TYPE ON GROUND AND ALL OTHER FLOOR	H1B-G1K	H1B-G1K
31	AUTOMATIC RESCUE DEVICE , EMERGENCY LANDING DEVICE	PROVIDED	PROVIDED

Page 8 of 14

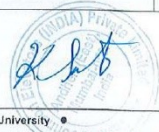

Atmiya University  
● Atmiya Institute of Technology & Science for Diploma Studies ● Shree Manibhai Virani & Sint. Navatben Virani Science College ●  
● Shree Atmiya Shishu Vidyamandir ● Shree Sarveshwar Vidyamandir ●

Registrar  
Atmiya University  
Rajkot







|| SWAMI SHREEJI ||

## SARVODAY KELAVANI SAMAJ

Trust Registration. No. F - 28, (RAJKOT)

"YOGIDHAM GURUKUL", KALAWAD ROAD, RAJKOT - 360 005

● PRESIDENT : H.D.H. P.P. HARIPRASAD SWAMIJIMAHARAJ  
● SECRETARY : SADHU TYAGVALLABHDASJI

Ph. : +91 - 281 - 2563555 | Fax : +91 - 281 - 2563952

E-mail : yogidhamrajkot@yahoo.com | Website : www.sks.ac.in

32	CAR ARRIVAL CHIME , ROLLER GUIDE SHOES FOR CAR & CWT ,OIL BUFFERS	PROVIDED	PROVIDED
33	FIRE EMERGENCY OPERATION ,ALARM BELL FOR FIREMEN'S OPERATION , FIREMEN'S OPERATION , EMERGENCY CABIN LIGHTING,EMERGENCY ALARM BUTTON, EMERGENCY INTERPHONE SYSTEM,THREE WAY INTERCOM SYSTEM	PROVIDED	PROVIDED
34	CABLE PROVIDE IN CAGE	PROVISION FOR EMS,TOUCHLESS PROVIDED	PROVISION FOR EMS,TOUCHLESS PROVIDED
35	CAR CALL CANCEL SYSTEM ,AUTOMATIC BYPASS, ATTENDANT OPERATION ,INDEPENDENT OPERATION ,OVERLOAD DETECTION ,MULTI-BEAM DOOR SENSOR	PROVIDED	PROVIDED
36	SAFE LANDING OPERATION,NEXT LANDING OPERATION,DOOR KNUDGING SAFETY OPERATION, EXPEDITING DOOR CLOSE OPERATION, RE-OPEN WITH HALL CALL BUTTON OPERATION	PROVIDED	PROVIDED
37	HAND OPERATION	INSPECTION MODE PROVIDED BUT TO BE USED ONLY BY MAINTENANCE TEAM	
38	EMERGENCY STOP BUTTON		N/A
39	HIGHEST CALL REVERSAL OPERATION	FALSE CAR CANCELLATION PROVIDED	
40	LOWEST CALL REVERSAL OPERATION		
41	DOOR LOAD DETECTOR	OVER LOAD INDICATOR PROVIDED IN ELEVATOR CABIN	
42	AUTOMATIC DOOR SPEED CONTROL,AUTOMATIC DOOR OPEN TIME ADJUSTMEN ,DOOR SENSOR SELF DIAGNOSIS OPERATION,	PROVIDED	PROVIDED
43	CLICK TYPE CAR AND HALL CALL BUTTON OPERATION	BUTTON TYPE HIB PROVIDED	BUTTON TYPE HIB PROVIDED
44	FALSE CALL CANCELLATION - FCC - P (BUTTON TYPE)	FALSE CAR CANCELLATION PROVIDED	FALSE CAR CANCELLATION PROVIDED
45	EMS SOFTWARE DETAIL		As per Annexure - III
46	TOUCH LESS SYSTEM IN CAR AND HALL CALL DETAIL	PROVIDED	PROVIDED
47	MANUAL AND AUTO CALL ATTENDED SYSTEM	ATTENDANT MODE PROVIDED	ATTENDANT MODE PROVIDED
48	ELEVATORS PARKING DETAIL	MAIN FLOOR AS PARKING FLOOR PROVIDED BY DEFAULT	MAIN FLOOR AS PARKING FLOOR PROVIDED BY DEFAULT

Page 9 of 14

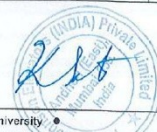
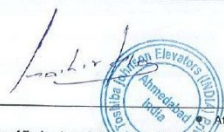

● Atmiya Institute of Technology & Science for Diploma Studies ● Shree Manibhai Virani & Smt. Navalben Virani Science College ● Shree Atmiya Shriya Vidya Mandir ● Shree Sarveshwar Vidya Mandir ●

**Registrar  
Atmiya University  
Rajkot**





SHRI SWAMI SHREEJIJI

**SARVODAY KELAVANI SAMAJ**

Trust Registration No: F-28, (RAJKOT)

"YOGIDHAM GURUKUL", KALAWAD ROAD, RAJKOT - 360 005

● PRESIDENT H.D.H. P.P. HARIPRASAD SWAMIJI(MAHARAJ)  
● SECRETARY S.SOHU TYAGVALLABHDASJI

Ph: +91-281-2563555 | Fax: +91-281-2563952  
E-mail: yogidham.rajkot@yhsuo.com | Website: www.sks.ac.in

Sl. No.	Elevators Description	Elevators Name / Model No./Type/Finish	Elevators Capacity / Type/Finish
1	MODEL NO.	P9(612)-105MPM 12/12 -- S/O 2S -MR	P9(612)-105MPM 77 -S/O - CO -MR
2	QUANTITY/USAGE	2/PASSENGER	1/PASSENGER
3	CAPACITY IN KGS	612	612
4	NO. OF PERSON /CABIN TYPE	9 /WIDER CABIN	9/ WIDER CABIN
5	SPEED /CONTROL	1.75 mps /VVVF	1.75 mps /VVVF
6	MOTOR CAPACITY (KW)	SHALL BE SUBMITTED DURING GAD SUBMISSION	
7	OPERATION	SIMPLEX COLLECTIVE OPERATION WITH EMS	
8	NO. OF STOP/OPENING	12	7
9	FLOOR DESIGNATION	B2,B1,G,1-9	B2,B1,G,1-4
10	TRAVEL IN METERS	AS PPER BUILDING DRAWINGS / SITE CONDITION	
11	HOIST WAY SIZE AVAILABLE/REAUURED (W*D)	1800*1800 MM	1800*1800 MM
12	PIT DEPTH AVAILABE/REQUIRED(MM)	1450 MM	1450 MM
13	OVERHEAD HEIGHT AVAILABLE/REQUIRED (MM)	AS PER SITE	AS PER SITE
14	LOCATION OF MACHINE	ABOVE THE HOISTWAY	ABOVE THE HOISTWAY
15	DOOR OPENING ARRAGEMENT	TWO SIDE TELESCOPIC OPENING (FRONT SIDE B2,B1,G,1 TO 5 AND REAR SIDE: 6 TO 9)	CENTRE OPENING
16	CAR INTERNAL SIZE (WxDxH)	1200 X 1100 X 2300MM	1300 X 1200 X 2300 MM
17	CAR DOOR WIDTH X HEIGHT (MM)	800 X 2100 MM	800 X 2100 MM
18	POWER SUPPLY	415V , 50HZ	415V , 50HZ
19	CABIN LIGHTING POWER SUPPLY	220V	220V
20	CABIN CEILING TYPE AND MATERIAL	SL - 1 IN STAINLESS STEEL HAIRLINE FINISH	
21	CABIN VENTILATION	2 NOS OF BLOWER PROVIDED	
22	CABIN FLOORING	IN CUSTOMER'S SCOPE	
23	CAR AND LANDING SILLS	ALUMINUM	
24	ENTRANCE JAMBS TYPE & FINISH ON GR. AND OTHER FLOORS	NARROW JAMB IN SUS HL	NARROW JAMB IN SUS HL
25	LANDING DOORS ( FINISH ) ON GROUND AND ALL OTHER FLOOR	IN STAINLESS STEEL HAIRLINE FINISH	IN STAINLESS STEEL HAIRLINE FINISH
26	CABIN OPERATING PANEL TYPE	COP-GIK WITH DOT MATRIX INDICATOR	COP-GIK WITH DOT MATRIX INDICATOR
27	BUTTON TYPE FOR COP AND HALL INDICATOR	KB-7	KB-7
28	BUTTON COLOR	ORANGE	ORANGE
29	FACE PLATE FINISH FOR COP AND HALL INDICATOR	IN STAINLESS STEEL HAIRLINE FINISH	IN STAINLESS STEEL HAIRLINE FINISH
30	HALL INDICATOR TYPE ON GROUND AND ALL OTHER FLOOR	HIB-GIK	HIB-GIK
31	AUTOMATIC RESCUE DEVICE , EMERGENCY LANDING DEVICE	PROVIDED	PROVIDED

Page 10 of 14



*Handwritten signature*



Atmiya Institute of Technology & Science (AIT&S) - Atmiya University, Shree Mahatma Virani & Shri. Navabhai Virani Science College, Shree Atmiya Shishu Vidyanandri, Shree Sarvodaya Vidyanandri

*Handwritten signature*

**Registrar  
Atmiya University  
Rajkot**







II SWAMI SHREEJI II

## SARVODAY KELAVANI SAMAJ

Trust Registration. No. F - 28, (RAJKOT)

"YOGIDHAM GURUKUL", KALAWAD ROAD, RAJKOT - 360 005

● PRESIDENT : H.D.H. P.P. HARIPRASAD SWAMIJIMAHARAJ  
● SECRETARY : SADHU TYAGVALLABHDASJI

Ph : +91 -281 - 2563555 | Fax : +91 - 281 - 2563952  
E-mail : yogidhamrajkot@yahoo.com | Website : www.sks.ac.in

1	MODEL NO.	P9(612)-105MPM 12/12 -- S/O 2S -MR	P9(612)-105MPM 7/7 -S/O - CO -MR
2	QUANTITY/USAGE	2/PASSENGER	1/PASSENGER
3	CAPACITY IN KGS	612	612
4	NO. OF PERSON /CABIN TYPE	9 /WIDER CABIN	9/ WIDER CABIN
5	SPEED /CONTROL	1.75 mps /VVVF	1.75 mps /VVVF
6	MOTOR CAPACITY (KW)	SHALL BE SUBMITTED DURING GAD SUBMISSION	
7	OPERATION	SIMPLEX COLLECTIVE OPERATION WITH EMS	
8	NO. OF STOP/OPENING	12	7
9	FLOOR DESIGNATION	B2,B1,G,1-9	B2,B1,G,1-4
10	TRAVEL IN METERS	AS PPER BUILDING DRA WINGS / SITE CONDITION	
11	HOIST WAY SIZE AVAILABLE/REAIURED (W*D)	1800*1800 MM	1800*1800 MM
12	PIT DEPTH A VAILABLE/REQUIRED(MM)	1450 MM	1450 MM
13	OVERHEAD HEIGHT AVAILABLE/REQUIRED (MM)	AS PER SITE	
14	LOCATION OF MACHINE	ABOVE THE HOISTWAY	ABOVE THE HOISTWAY
15	DOOR OPENING ARRAGEMENT	TWO SIDE TELESCOPIC OPENING (FRONT SIDE B2,B1,G,1 TO 5 AND REAR SIDE 6 TO 9)	CENTRE OPENING
16	CAR INTERNAL SIZE (WxDxH)	1200 X 1100 X 2300MM	1300 X 1200 X 2300 MM
17	CAR DOOR WIDTH X HEIGHT (MM)	800 X 2100 MM	800 X 2100 MM
18	POWER SUPPLY	415V , 50HZ	415V , 50HZ
19	CABIN LIGHTING POWER SUPPLY	220V	220V
20	CABIN CEILING TYPE AND MATERIAL	SL - 1 IN STAINLESS STEEL HAIRLINE FINISH	
21	CABIN VENTILATION	2 NOS OF BLOWER PROVIDED	
22	CABIN FLOORING	IN CUSTOMER'S SCOPE	
23	CAR AND LANDING SILLS	ALUMINUM	
24	ENTRANCE JAMBS TYPE & FINISH ON GR. AND OTHER FLOORS	NARROW JAMB IN SUS HL	NARROW JAMB IN SUS HL
25	LANDING DOORS ( FINISH ) ON GROUND AND ALL OTHER FLOOR	IN STAINLESS STEEL HAIRLINE FINISH	IN STAINLESS STEEL HAIRLINE FINISH
26	CABIN OPERATING PANEL TYPE	COP-GIK WITH DOT MATRIX INDICATOR	COP-GIK WITH DOT MATRIX INDICATOR
27	BUTTON TYPE FOR COP AND HALL INDICATOR	KB-7	KB-7
28	BUTTON COLOR	ORANGE	
29	FACE PLATE FINISH FOR COP AND HALL INDICATOR	IN STAINLESS STEEL HAIRLINE FINISH	IN STAINLESS STEEL HAIRLINE FINISH
30	HALL INDICATOR TYPE ON GROUND AND ALL OTHER FLOOR	HIB-GIK	HIB-GIK
31	AUTOMATIC RESCUE DEVICE , EMERGENCY LANDING DEVICE	PROVIDED	

Page 10 of 14



*Handwritten signature*

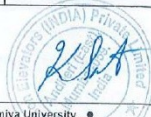

Atmiya University  
Atmiya Institute of Technology & Science for Diploma Studies • Shree Manibhai Virani & Smt. Navalben Virani Science College •  
• Shree Atmiya Shishu Vidyamandir • Shree Sarveshwar Vidyamandir •

*Handwritten signature*

**Registrar  
Atmiya University  
Rajkot**





॥ SWAMI SHREEJI ॥

## SARVODAY KELAVANI SAMAJ

Trust Registration No. F - 28, (RAJKOT)

"YOGIDHAM GURUKUL", KALAWAD ROAD, RAJKOT - 360 005

● PRESIDENT : H.D.H. P.P. HARIPRASAD SWAMIJIMAHARAJ  
● SECRETARY : SADHU TYAGVALLABHDASJI

Ph. : +91 - 281 - 2563555 | Fax : +91 - 281 - 2563952  
E-mail : yogidhamrajkot@yahoo.com | Website : www.sks.ac.in

32	CAR ARRIVAL CHIME , ROLLER GUIDE SHOES FOR CAR & CWT, OIL BUFFERS	PROVIDED	PROVIDED
33	FIRE EMERGENCY OPERATION ,ALARM BELL FOR FIREMEN'S OPERATION , FIREMEN'S OPERATION , EMERGENCY CABIN LIGHTING,EMERGENCY ALARM BUTTON, EMERGENCY INTERPHONE SYSTEM,THREE WAY INTERCOM SYSTEM	PROVIDED	PROVIDED
34	CABLE PROVIDE IN CAGE	PROVISION FOR EMS, TOUCHLESS PROVIDED	PROVISION FOR EMS, TOUCHLESS PROVIDED
35	CAR CALL CANCEL SYSTEM ,AUTOMATIC BYPASS ,ATTENDANT OPERATION ,INDEPENDENT OPERATION ,OVERLOAD DETECTION ,MULTI-BEAM DOOR SENSOR	PROVIDED	PROVIDED
36	SAFE LANDING OPERATION,NEXT LANDING OPERATION,DOOR KNUDGING SAFETY OPERATION, EXPEDITING DOOR CLOSE OPERATION, RE-OPEN WITH HALL CALL BUTTON OPERATION	PROVIDED	PROVIDED
37	HAND OPERATION	INSPECTION MODE PROVIDED BUT TO BE USED ONLY BY MAINTENANCE TEAM	
38	EMERGENCY STOP BUTTON	N/A	
39	HIGHEST CALL REVERSAL OPERATION	FALSE CAR CANCELLATION PROVIDED	
40	LOWEST CALL REVERSAL OPERATION		
41	DOOR LOAD DETECTOR	OVER LOAD INDICATOR PROVIDED IN ELEVATOR CABIN	
42	AUTOMATIC DOOR SPEED CONTROL,AUTOMATIC DOOR OPEN TIME ADJUSTMEN ,DOOR SENSOR SELF DIAGNOSIS OPERATION,	PROVIDED	PROVIDED
43	CLICK TYPE CAR AND HALL CALL BUTTON OPERATION	BUTTON TYPE HIB PROVIDED	BUTTON TYPE HIB PROVIDED
44	FALSE CALL CANCELLATION - FCC - P (BUTTON TYPE)	FALSE CAR CANCELLATION PROVIDED	FALSE CAR CANCELLATION PROVIDED
45	EMS SOFTWARE DETAIL	AS PER ANNEXURE -III	
46	TOUCH LESS SYSTEM IN CAR AND HALL CALL DETAIL	PROVIDED	PROVIDED
47	MANUAL AND AUTO CALL ATTENDED SYSTEM	ATTENDANT MODE PROVIDED	ATTENDANT MODE PROVIDED
48	ELEVATORS PARKING DETAIL	MAIN FLOOR AS PARKING FLOOR PROVIDED BY DEFAULT	MAIN FLOOR AS PARKING FLOOR PROVIDED BY DEFAULT

Page 11 of 14

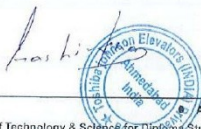

Atmiya University • Atmiya Institute of Technology & Science for Diploma Studies • Shree Mangibhai Virani & Smt. Navalben Virani Science College • Shree Atmiya Shiksha Vidyamandir • Shree Sarveshwar Vidyamandir •

**Registrar**  
**Atmiya University**  
**Rajkot**







॥ SWAMI SHREEJI ॥

## SARVODAY KELAVANI SAMAJ

Trust Registration No. F - 28, (RAJKOT)

"YOGIDHAM GURUKUL", KALAWAD ROAD, RAJKOT - 360 005

● PRESIDENT : H.D.H. P.P. HARIPRASAD SWAMIJIMAHARAJ  
● SECRETARY : SADHU TYAGVALLABHDASJI

Ph. : +91 - 281 - 2563555 | Fax : +91 - 281 - 2563952  
E-mail : yogidhamrajkot@yahoo.com | Website : www.sks.ac.in

32	CAR ARRIVAL CHIME , ROLLER GUIDE SHOES FOR CAR & CWT, OIL BUFFERS	PROVIDED	PROVIDED
33	FIRE EMERGENCY OPERATION ,ALARM BELL FOR FIREMEN'S OPERATION , FIREMEN'S OPERATION , EMERGENCY CABIN LIGHTING,EMERGENCY ALARM BUTTON, EMERGENCY INTERPHONE SYSTEM,THREE WAY INTERCOM SYSTEM	PROVIDED	PROVIDED
34	CABLE PROVIDE IN CAGE	PROVISION FOR EMS, TOUCHLESS PROVIDED	PROVISION FOR EMS, TOUCHLESS PROVIDED
35	CAR CALL CANCEL SYSTEM ,AUTOMATIC BYPASS ,ATTENDANT OPERATION ,INDEPENDENT OPERATION ,OVERLOAD DETECTION ,MULTI-BEAM DOOR SENSOR	PROVIDED	PROVIDED
36	SAFE LANDING OPERATION,NEXT LANDING OPERATION,DOOR KNUDGING SAFETY OPERATION, EXPEDITING DOOR CLOSE OPERATION, RE-OPEN WITH HALL CALL BUTTON OPERATION	PROVIDED	PROVIDED
37	HAND OPERATION	INSPECTION MODE PROVIDED BUT TO BE USED ONLY BY MAINTENANCE TEAM	
38	EMERGENCY STOP BUTTON	N/A	
39	HIGHEST CALL REVERSAL OPERATION	FALSE CAR CANCELLATION PROVIDED	
40	LOWEST CALL REVERSAL OPERATION		
41	DOOR LOAD DETECTOR	OVER LOAD INDICATOR PROVIDED IN ELEVATOR CABIN	
42	AUTOMATIC DOOR SPEED CONTROL,AUTOMATIC DOOR OPEN TIME ADJUSTMEN ,DOOR SENSOR SELF DIAGNOSIS OPERATION,	PROVIDED	PROVIDED
43	CLICK TYPE CAR AND HALL CALL BUTTON OPERATION	BUTTON TYPE HIB PROVIDED	BUTTON TYPE HIB PROVIDED
44	FALSE CALL CANCELLATION - FCC - P (BUTTON TYPE)	FALSE CAR CANCELLATION PROVIDED	FALSE CAR CANCELLATION PROVIDED
45	EMS SOFTWARE DETAIL	AS PER ANNEXURE -III	
46	TOUCH LESS SYSTEM IN CAR AND HALL CALL DETAIL	PROVIDED	PROVIDED
47	MANUAL AND AUTO CALL ATTENDED SYSTEM	ATTENDANT MODE PROVIDED	ATTENDANT MODE PROVIDED
48	ELEVATORS PARKING DETAIL	MAIN FLOOR AS PARKING FLOOR PROVIDED BY DEFAULT	MAIN FLOOR AS PARKING FLOOR PROVIDED BY DEFAULT

Page 11 of 14



Atmiya University • Atmiya Institute of Technology & Science for Diploma Studies • Shree Mangibhai Virani & Smt. Navalben Virani Science College • Shree Atmiya Shiksha Vidyamandir • Shree Sarveshwar Vidyamandir •

*[Handwritten Signature]*

**Registrar  
Atmiya University  
Rajkot**





॥ SWAMI SHREEJI ॥

## SARVODAY KELAVANI SAMAJ

Trust Registration No. F - 28, (RAJKOT)

"YOGIDHAM GURUKUL", KALAWAD ROAD, RAJKOT - 360 005

● PRESIDENT : H.D.H. P.P. HARIPRASAD SWAMIJIMAHARAJ  
● SECRETARY : SADHU TYAGVALLABHDASJI

Ph. : +91 - 281 - 2583555 | Fax : +91 - 281 - 2563952

E-mail : yogidhamrajkot@yahoo.com | Website : www.sks.ac.in

### Annexure – III

#### Detail specifications of Toshiba Elevators Monitoring for ELCOSMO-III Auto Door Machine Room Lift

**Touch less Solution for Hall Call: Gesture Calling**  
Swing your hands or reach near to car/hall call button of respective floor then call will be registered without touching the elevator buttons.

**Elevators monitoring system (EMS) required below mention facility and Feature**

#### Control System

The computer connected to the EMS system can control the special/ Normal and emergency operations of the elevators by Manual Non Service floor/floor lockout, Parking operation

**Manual:** Means authorized user can control normal and emergency operation on/off manually.

#### Monitoring System:

**Elevator Monitoring System** monitors the elevators attached to the system and provides real-time display screens with various layouts for system monitoring.

**Monitoring Dashboard:** This Screen shows operation status of all elevators with respective group like Floor Status, Power supply (Normal/standby), elevator name, direction (up/down), run status (normal, inactive, error, etc.), maintenance, emergency status, operation by emergency power Swag Emergency etc...

**Plan Layout:** This Layout shows the status information with (normal/emergency, Door (Open/Close) Status, elevator up/down direction, elevators normal/emergency /breakdown status, elevators auto and manual mode.

**Layout Status:** This screen shows the location of elevators in building /campus.

**Static Layout:** This layout shows the status information of all elevators in group. Information like group and elevators no. floor status, load, mode status (Auto/VIP/Manual).

**Play Back System:** Past all elevators movement with status can be recorded for a maximum of 6 months which is connected in EMS and playback for a specified period of time and date.

**Traffic Analysis System:** This dash board shows the result of actual traffic during a specified period on basic of statistical data in past 6 months with Record Abnormal Operations, Record Critical [Alarms] Condition, Landing Call Analysis, Statistics Analysis of Calls, Average Landing Call Waiting Times, Maximum Waiting Times, Breakdown reports

**History :** To search and print Alarm and Operation history for specified period of time and date wise for all elevators

**Security Lock System:** To use control, playback, traffic analysis and monitoring function by entering respective username and user's password.

**Note: - Wiring from Machine room to BMS room in client Scope.**

**Force Majeure:** Under no circumstances shall either of us be liable for any loss, damage or delay due to any cause beyond our reasonable control at the time of natural calamities such as earthquake, tsunami and cyclone at the time of explosion & riots. In that case this agreement may also be terminated at any time by either party within 28 weeks from the date of your acceptance of this proposal here under on 30 days prior notification in writing.

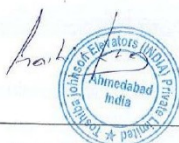

Page 12 of 14

● Atmiya University ●  
● Atmiya Institute of Technology & Science for Diploma Studies ● Shree Manibhai Virani & Smt. Navalben Virani Science College ●  
● Shree Atmiya Shishu Vidyamandir ● Shree Sarveshwar Vidyamandir ●

**Registrar  
Atmiya University  
Rajkot**







॥ SWAMI SHREEJI ॥

## SARVODAY KELAVANI SAMAJ

Trust Registration No. F - 28, (RAJKOT)

"YOGIDHAM GURUKUL", KALAWAD ROAD, RAJKOT - 360 005

● PRESIDENT : H.D.H. P.P. HARIPRASAD SWAMIJIMAHARAJ  
● SECRETARY : SADHU TYAGVALLABHDASJI

Ph. : +91 - 281 - 2563555 | Fax : +91 - 281 - 2563952  
E-mail : yogidhamrjkot@yahoo.com | Website : www.sks.ac.in

**Security Export Control :** The materials, technology, software for elevators /escalators supplied by Toshiba Johnson Elevators shall not be used for the development, production, use or weapons of mass destructions as well as military applications or shall not transfer/sell the items to any third party should customer know or suspect that those can be used for such application.

**BOCW :** Toshiba Johnson Elevators (TJEL) will not liable for any BOCW labour-cess payment arising out of BOCW license (if applicable to us) whether directly or indirectly.

❖ **Brief list of various works related to be undertaken by customer**

1. Civil & Electrical / Building related work:
2. Entire civil works including chipping, grouting, finished, painting, etc.
3. To furnish a property framed and enclosed elevator hoist way including, if necessary, its extension above the roof. The hoist way will be treated and painted to eliminate the accumulation and circulation of dust.
4. To furnish an elevator pit of proper and legal depth (As per Annexure-II) below the lowest landing and, if required, suitable drains and waterproofing.
5. To design, furnish and install the hoist way structures required to withstand the forces and loads resulting from use of the elevator.
6. To provide 3-phase power supply in Lift Machine Room and inside the shaft during installation in free of cost as agreed.
7. To do all painting, except of elevator materials.
8. To furnish and install power, signal and light connections as follow.
  - a) To terminal studs to controller or starter including suitable fused is connect switch in elevator machine rooms.
  - b) To relay panel with fused, disconnect switch in elevator machine room when required.
  - c) To light outlet in the machine rooms.
9. To provide and fix carpets/ marble for elevator cabin floors.
10. To provide suitably weatherproof lockable storage space for elevator materials at the ground/Basement floor level, preferably near the elevator hoist-way.
11. To provide Shaft separate channel and wire mesh between to separate channel inside hoist-way as elevator separation. (Applicable only in shafts where full RCC side wall is not provided)
12. To do all cutting of walls, floors or partition together with any repairs made necessary thereby, including grouting of all bolts, sills, steel members, indicator and button boxes, architraves etc.
13. Any decorative lipping work around the entrance frames at all floors after the entrance frames have been fixed.

Page 13 of 14



● Atmiya Institute of Technology & Science for Diploma Studies ● Shree Manjibhai Virani & Smt. Navalben Virani Science College ●  
● Shree Atmiya Shishu Vidyamandir ● Shree Sarvashwar Vidyamandir ●

**Registrar  
Atmiya University  
Rajkot**





II SWAMI SHREEJI II

## SARVODAY KELAVANI SAMAJ

Trust Registration No. F - 28, (RAJKOT)

"YOGIDHAM GURUKUL", KALAWAD ROAD, RAJKOT - 360 005

● PRESIDENT : H.D.H. P.P. HARI PRASAD SWAMIJIMAHARAJ  
● SECRETARY : SADHU TYAGVALLABHDASJI

Ph. : +91 - 281 - 2563555 | Fax : +91 - 281 - 2563952  
E-mail : yogidhamrajkot@yahoo.com | Website : www.sks.ac.in

14. To get the best performance from the equipment, you should restrict the temperature in the machine room to a maximum of 40 deg. Centigrade and the humidity to 90% apart from protecting the machine room and the hoist way from sand and dust by suitable means.
15. To provide hoisting beams / hooks in the machine room bottom slab ceiling / escalator floors and supply, install ladder access in pit and machine rooms.
16. If there is tower crane /fork lift facility at site, the elevator contractor should be allowed its use free of cost for hoisting machinery to the machine room and for unloading of the materials from the containers and to store the same at various locations.
17. To furnish in the machine rooms during the erection of elevators, electric power of the necessary characteristics to provide illumination, operation of required tools and hoist for testing and adjustment of elevators.
18. To furnish and install circuit breakers, ELCB's suitable earthing leads at machine room or other devices necessary for each elevator to meet the local Government requirements (Details shall be provided by TJEI)
19. To supply and install "fire alarm sensing contacts", emergency generator operation, sensing relay contacts and it related wiring in machine rooms, if required by TJEI.
20. Cutting of marble for fixing back box and hall position indicator at all floors.
21. To provide drinking water & all sanitary facilities to our installation crew during the time of execution of our work.
22. To provide structural support at every 2500 mm level throughout the hoist way to fix the wall / guide rail brackets. (Applicable only in shafts where full RCC side wall is not provided)
23. The multiple shifting of elevator or escalator materials from the main stores shall be carried out by the customer /others and free of any additional cost to Toshiba Elevators.
24. To furnish permanent 3 phase, 50 Hz, 415 V (+ 5% -- 10%) for power supply be terminated in suitably rated MCCB/ ELCB at last slab/machine room.
25. Any charges towards Govt. Authority for obtaining the license shall be borne by the Client, TJEI shall coordinate and provide all type of technical document to obtain license.
26. Storage space for the elevator materials shall be provided by the Client with lock & key arrangement at site. However, security shall be in TJEI scope.



Page 14 of 14

● Atmiya University ●  
● Atmiya Institute of Technology & Science for Diploma Studies ● Shree Manibhai Virani & Smt. Navalben Virani Science College ●  
● Shree Atmiya Shishu Vidyamandir ● Shree Sarveshwar Vidyamandir ●

**Registrar**  
**Atmiya University**  
**Rajkot**







**OUTCOME & IMPACT**

**Patent for SMART LIGHTING SYSTEM FOR ENERGY CONSERVATION**

(12) PATENT APPLICATION PUBLICATION

(21) Application No.202421045036 A

(19) INDIA

(22) Date of filing of Application :11/06/2024

(43) Publication Date : 19/07/2024

(54) Title of the invention : SMART LIGHTING SYSTEMS FOR ENERGY CONSERVATION

(51) International classification :I05B0047110000, F21V0023040000, F04N0005330000, F05B0047100000, F21S0002000000

(86) International Application No :NA  
Filing Date :NA

(87) International Publication No :NA

(61) Patent of Addition to Application Number :NA  
Filing Date :NA

(62) Divisional to Application Number :NA  
Filing Date :NA

(71)Name of Applicant :

1)Atmiya University  
Address of Applicant :Atmiya University, "Yogidham Gurukul", Kalawad Road, Rajkot – 360005, Gujarat, India Rajkot -----

2)Dr. Ashish M. Kotbari

Name of Applicant : NA

Address of Applicant : NA

(72)Name of Inventor :

1)Dr. Ashish M. Kotbari

Address of Applicant :Director-Research, Innovation & Translation, Atmiya University, "Yogidham Gurukul", Kalawad Road, Rajkot – 360005 Rajkot -----

(57) Abstract :

Abstract Smart Lighting Systems for Energy Conservation The present invention provides a smart lighting system designed to conserve energy by automatically adjusting illumination based on ambient light conditions and human occupancy. The system includes a Light Dependent Resistor (L) sensor to monitor ambient light levels and a Passive Infrared (P) sensor to detect human motion. An Arduino UNO microcontroller (M) processes the input from these sensors to control a switching module (SM), which activates the lighting only when necessary. The system allows for customizable settings, enabling users to adjust the ambient light threshold and the duration for which the lights remain on after motion detection. This smart lighting system significantly reduces energy wastage, lowers electricity bills, and contributes to environmental sustainability. It is versatile and applicable in various indoor and outdoor environments, such as staircases, parking areas, building lobbies, halls, porches, decks, and backyards. Figure 1

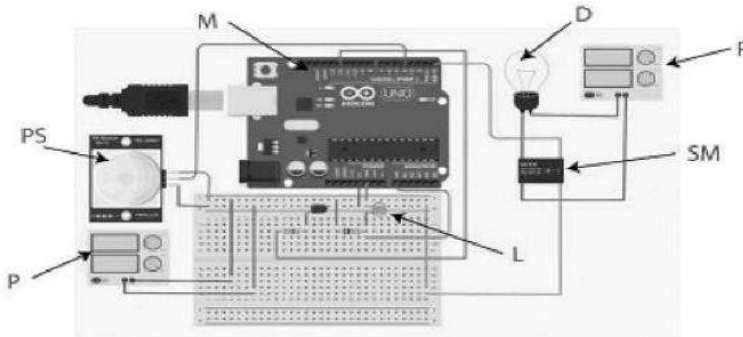

Figure 1 shows diagram of smart lighting system

No. of Pages : 16 No. of Claims : 7

The Patent Office Journal No. 29/2024 Dated: 19/07/2024

**Registrar  
Atmiya University  
Rajkot**





### Power Consumption Comparison

Particular	LED Light without Sensor	LED Light with Motion Sensor	Inhouse Invented, Developed & Installed LED Bulb
Power Consumption per Lightig Fixture (kWh)	$18 \times 12 \times 300 / 1000 = 64.8$	$18 \times (600 \times 30 / 3600) \times 300 / 1000 = 27$	$18 \times (200 \times 30 / 3600) \times 300 / 1000 = 9$
Power Consumption by 100 Lightig Fixtures (kWh)	6,480	2,700	900
Cost of Power Consumption of 100 Lighting Fixtures (INR)	27,216	11,340	3,780
Carbon Emission (KgCO <sub>2</sub> e)	4,620	1,925	642

#### Assumptions:

1. No. of working days are 300 in a year, approximately.
2. Lighting fixtures are in ON state for 12 hours averagely in a day.
3. 600 movements are detected averagely in a working day.
4. Sensor based bulbs remain consume power for 30 seconds, when motion detected.
4. All lighting fixture are of 18 W power rating.

Prepared By:

**Seema Vachhani**  
Certified Energy Auditor  
Reg. No. EA-25555  
Bureau of Energy Efficiency, India.

Atmiya University

**Registrar**  
**Atmiya University**  
**Rajkot**









**Patent for Smart light system for Energy Conservation.**

(12) PATENT APPLICATION PUBLICATION

(21) Application No.202421045036 A

(19) INDIA

(22) Date of filing of Application :11/06/2024

(43) Publication Date : 19/07/2024

(54) Title of the invention : SMART LIGHTING SYSTEMS FOR ENERGY CONSERVATION

(51) International classification :H05B0047110000, F21V0023040000, H04N0005330000, H05B0047100000, F21S0002000000

(86) International Application No :NA  
Filing Date :NA

(87) International Publication No : NA

(61) Patent of Addition to Application Number :NA  
Filing Date :NA

(62) Divisional to Application Number :NA  
Filing Date :NA

(71)Name of Applicant :

1)Atmiya University  
Address of Applicant :Atmiya University, "Yogidham Gurukul", Kalawad Road, Rajkot – 360005, Gujarat, India Rajkot -----

2)Dr. Ashish M. Kothari

Name of Applicant : NA

Address of Applicant : NA

(72)Name of Inventor :

1)Dr. Ashish M. Kothari

Address of Applicant :Director-Research, Innovation & Translation, Atmiya University, "Yogidham Gurukul", Kalawad Road, Rajkot – 360005 Rajkot -----

(57) Abstract :

Abstract Smart Lighting Systems for Energy Conservation The present invention provides a smart lighting system designed to conserve energy by automatically adjusting illumination based on ambient light conditions and human occupancy. The system includes a Light Dependent Resistor (L) sensor to monitor ambient light levels and a Passive Infrared (P) sensor to detect human motion. An Arduino UNO microcontroller (M) processes the input from these sensors to control a switching module (SM), which activates the lighting only when necessary. The system allows for customizable settings, enabling users to adjust the ambient light threshold and the duration for which the lights remain on after motion detection. This smart lighting system significantly reduces energy wastage, lowers electricity bills, and contributes to environmental sustainability. It is versatile and applicable in various indoor and outdoor environments, such as staircases, parking areas, building lobbies, halls, porches, decks, and backyards. Figure 1

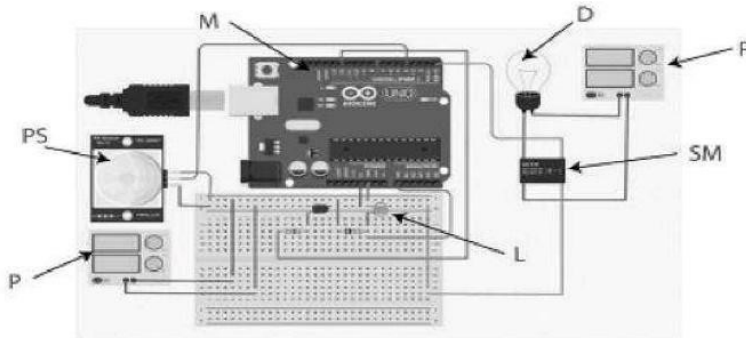

Figure 1 shows diagram of smart lighting system

No. of Pages : 16 No. of Claims : 7

**Registrar  
Atmiya University  
Rajkot**







**ATMIYA UNIVERSITY**

**NAAC – Cycle – 1  
AISHE: U-0967**

**Criterion- VII**

**IV&BP**

**KI 7.2**

**M 7.2.1**

**BILLS FOR PURCHASE OF EQUIPMENT'S**

**Retail Invoice (Debit)** (ORIGINAL FOR RECIPIENT)

**CHANDAN ELECTRIC SERVICE**  
Sneh Ashish"  
New Jagnath, Rajkot - 360001  
GSTIN/UIN: 24ABJPC0071B1ZJ  
State Name : Gujarat, Code : 24  
Contact : 9909905526/9429501677  
E-Mail : chandaneleservice@yahoo.com  
Buyer (Bill to)  
**Atmiya University-Faculty of Science**  
Rajkot  
State Name : Gujarat, Code : 24

Invoice No. <b>R-22</b>	Dated <b>27-Apr-23</b>
Delivery Note <b>14</b>	Reference No. & Date.
Other References	Buyer's Order No.
Dated	Dispatch Doc No.
Delivery Note Date <b>3-Apr-23</b>	Dispatched through
Destination	

Sl No.	Description of Goods	HSN/SAC	GST Rate	Quantity	Rate	per	Disc. %	Amount
1	Havells Ventilating Fan DXW 150mm	84145190	18 %	1 Nos	2,915.00	Nos	41 %	1,719.85
2	Havells Ventilating Fan DX 200mm	84145190	18 %	3 Nos	2,200.00	Nos	41 %	3,894.00
	<i>Exhaust fan</i>							5,613.85
								C Gst 505.25
								S Gst 505.25
								Round Off (-)0.35

**PAID**

Ch. No. **Axis 385901823**

Bank **Axis**

Date **21/05/23**

Total	<b>4 Nos</b>	<b>₹ 6,624.00</b>
-------	--------------	-------------------

Prev Balance  
Bill Amount **6,624.00 Dr**  
Net Balance **6,624.00 Dr**  
Amount Chargeable (in words)  
**INR Six Thousand Six Hundred Twenty Four Only**

Company's Bank Details  
Bank Name : Hdfc Bank  
A/c No. : 50200040487961  
Branch & IFS Code : Dr. Yagnik Road & HDFC0000101  
for CHANDAN ELECTRIC SERVICE

Declaration  
We declare that this invoice shows the actual price of the goods described and that all particulars are true and correct.

Authorized Signatory

This is a Computer Generated Invoice

**Registrar  
Atmiya University  
Rajkot**





**ATMIYA  
UNIVERSITY**

**NAAC – Cycle – 1  
AISHE: U-0967**

**Criterion- VII**

**IV&BP**

**KI 7.2**

**M 7.2.1**

**Tax Invoice** (ORIGINAL FOR RECIPIENT)

**CHANDAN ELECTRIC SERVICE**  
"Sneh Ashish"  
New Jagnath, Rajkot - 360001  
Contact : 9909905526/9429501677  
E-Mail : chandaneleservice@yahoo.com  
GSTIN/UIN: 24ABJPC0071B1ZJ  
State Name : Gujarat, Code : 24

Invoice No. **ES/2634/23-24**  
Date **10-Oct-23**  
Delivery Note  
**3007**  
Reference No. & Date. Other References  
Buyer's Order No. Dated  
Dispatch Doc No. Delivery Note Date  
Dispatched through **29-Sep-23**  
Destination

Buyer (Bill to)  
**Atmiya University - FOS**  
Faculty of Science, Rajkot  
State Name : Gujarat, Code : 24

SI No.	Description of Goods	HSN/SAC	GST Rate	Quantity	Rate	per	Disc. %	Amount	
	Order No- 3007 Date 29-9-2023 <b>Exhaust Fan</b>	84145190	18 %	1 Nos	4,675.00	Nos	40 %	2,805.00	
								252.45	
								252.45	
								0.10	
<b>Total</b>								<b>1 Nos</b>	<b>3,310.00</b>

Prev Balance  
Bill Amount **3,310.00 Dr**  
Net Balance **3,310.00 Dr**  
Amount Chargeable (in words)  
**INR Three Thousand Three Hundred Ten Only**

Company's Bank Details  
Bank Name : Hdfc Bank  
A/c No. : 60200040487961  
Branch & IFS Code : Dr.Yagnik Road & HDFC0000101  
for CHANDAN ELECTRIC SERVICE

Declaration  
We declare that this invoice shows the actual price of the goods described and that all particulars are true and correct.

Authorized Signatory

This is a Computer Generated Invoice

**Registrar  
Atmiya University  
Rajkot**







**ATMIYA  
UNIVERSITY**

**NAAC – Cycle – 1  
AISHE: U-0967**

**Criterion- VII**

**IV&BP**

**KI 7.2**

**M 7.2.1**

**CHANDAN ELECTRIC CORPORATION**

20, NEW JAGANATH, PLOT MARUTI COMPLEX, RAJKOT-360005  
Phone: 0281-2467900 Email : chandanele.corp@gmail.com

**DEBIT RETAIL INVOICE ORIGINAL**

**To, ATMIYA UNIVERSITY (FOBC)**  
KALAWAD ROAD.  
**RAJKOT (Gujarat)**  
Ph. No:  
Party's GST No:

Invoice No: **R 96** Date: 25/04/2023  
Book No. :  
L.R. No.:  
Transport:  
Through:

Sr.	Particulars	HSN Code	Quantity	Rate	Dis.%	GST%	Amount
1	ORDER NO.: 1686 PANASONIC 20W LED BATTEN  Tube stick lead	94051100	20.00	180.00	15.25	18.00	3,050.86
			<b>20.00</b>	<b>Sub Total</b>			<b>3,050.86</b>

Bank Details: **HDFC BANK**  
A/C No: 50200065554518 IFSC CODE: HDFC0000101  
BRANCH: DR. YAGNIK ROAD

<b>Sub Total</b>						<b>3,050.86</b>	
SGST						274.58	
CGST						274.58	
Round Off						-0.02	
<b>Grand Total</b>						<b>3,600.00</b>	

**Rs. Three thousand six hundred only.**

GST No: 24ABFPC2693F2ZY  
TERMS:  
Subject to RAJKOT Jurisdiction.  
Payment 100% within 15 Days only.  
E. & O. E.

For: **CHANDAN ELECTRIC CORPORATION**  
Author: [Signature]

**PAID**  
Date: 25/04/2023  
Axb  
0205K3

[Signature]

**Registrar  
Atmiya University  
Rajkot**





**ATMIYA UNIVERSITY**

NAAC – Cycle – 1  
AISHE: U-0967

Criterion- VII

IV&BP

KI 7.2

M 7.2.1

**CHANDAN ELECTRIC CORPORATION**

20, NEW JAGANATH, PLOT MARUTI COMPLEX, RAJKOT-360005  
Phone: 0281-2467900 Email : chandanele.corp@gmail.com

**DEBIT RETAIL INVOICE ORIGINAL**

To, ATMIYA UNIVERSITY

Invoice No: R 244 Date: 02/06/2023

Book No. :  
L.R. No. :  
Transport: :  
Through: :

RAJKOT (Gujarat)  
Ph. No.:

Party's GST No:

Sr.	Particulars	HSN Code	Quantity	Rate	Dis. %	GST%	Amount
1	ORDER NO.: 1785 PANASONIC 20W LED BATTEN	94054010	45.00	180.00	15.25	18.00	6,864.43
2	ORDER NO.: 1795 PANASONIC 20W LED BATTEN	94054010	15.00	180.00	15.25	18.00	2,288.14
	<u>Tube Light Lead</u>						
			<b>60.00</b>				<b>9,152.57</b>

Bank Details: **HDFC BANK**  
A/C No: 50200065554518 IFSC CODE: HDFC0000101  
BRANCH: DR. YAGNIK ROAD

Sub Total: 9,152.57  
SGST: 823.73  
CGST: 823.73

GST Summary	Taxable Amt	SGST	SGST AMT	CGST	CGST AMT	Total GST
GST @18.00	9152.57	9.00	823.73	9.00	823.73	1647.46
<b>Total :</b>	<b>9152.57</b>		<b>823.73</b>		<b>823.73</b>	<b>1647.46</b>

Round Off: -0.03  
**Grand Total: 10,800.00**

Rs. Ten thousand eight hundred only.

GST No: 24ABFPC2693F2ZY

TERMS:  
Subject to RAJKOT Jurisdiction.  
Payment 100% within 15 Days only.  
E. & O. E.

For, CHANDAN ELECTRIC CORPORATION

**Registrar  
Atmiya University  
Rajkot**







**ATMIYA UNIVERSITY**

NAAC – Cycle – 1  
AISHE: U-0967

Criterion- VII

IV&BP

KI 7.2

M 7.2.1

**JIGNESH ELECTRIC STORES**

1 KOTAK STREET, CLOSE STREET, SANGANVA CHOWK RAJKOT-360001  
Phone: 9904100075 Email: jignesh\_ele\_stores@yahoo.co.in

**ORIGINAL**

**DEBIT INVOICE**

To, **ATMIYA UNIVERSITY FACULTY OF**  
BUSINESS & COMMERCE  
ATMIYA COLLAGE KALAWAD ROAD  
**RAJKOT (Gujarat)**  
Ph. No:  
Party's GST No:

Invoice No: **JE-776** Date: **26/08/2023**  
Challan No. : 44122 Date: 26/08/23  
Transport :  
L.R.No. : Date : / /  
Vehicle No. : No.of Case : 0.00

**Payment must be made within days.**

Sr.	Particulars	HSN Code	Quantity	Disc.	Rate	GST%	Amount
1	LED PL 18W <i>wipro</i>	94054010	50.00	15.254	410.00	18.00	17372.93
			<b>50.00</b>		<b>Sub Total</b>		<b>17,372.93</b>

**CLOSING BAL :0.00**

USHA TOLL FREE NO 1800 1033 111

GST Summary	Taxable Amnt	SGST	SGST AMT	CGST	CGST AMT	Total GST
GST @18.00	17372.93	9.00	1563.56	9.00	1563.56	3127.12
<b>Total :</b>	<b>17372.93</b>		<b>1563.56</b>		<b>1563.56</b>	<b>3127.12</b>

Sub Total **17,372.93**  
SGST **1,563.56**  
CGST **1,563.56**

Round Off **-0.00**

**Grand Total 20,500.00**

**Rs. Twenty thousand five hundred only.**

GST No: **24AARFJ0891K12W**  
Bank Details: **HDFC BANK LTD**  
A/C No: 50200058147440 IFSC CODE: HDFC0000101740  
BRANCH: Dr YAGNIK ROAD BRANCH,RAJKOT

For, **JIGNESH ELECTRIC STORES**

TERMS & CONDITIONS:  
1. GOODS ONCE SOLD WILL NOT BE TAKEN BACK.  
2. SUBJECT TO RAJKOT JURISDICTION. E.& O.E.

Authorized Signatory

PAID  
Axis 1500421266152  
Bank Axis  
Date 02/09/23

*[Handwritten Signature]*

**Registrar  
Atmiya University  
Rajkot**





**ATMIYA  
UNIVERSITY**

**NAAC – Cycle – 1  
AISHE: U-0967**

**Criterion- VII**

**IV&BP**

**KI 7.2**

**M 7.2.1**

**CHANDAN ELECTRIC CORPORATION**

20, NEW JAGANATH, PLOT MARUTI COMPLEX, RAJKOT-360005  
Phone: 0281-2467900 Email: chandanelec.corp@gmail.com

**DEBIT RETAIL INVOICE ORIGINAL**

To, ATMIYA UNIVERSITY (FOBC)

KALAWAD ROAD.

RAJKOT (Gujarat)

Ph. No:

Party's GST No:

Invoice No: R 640 Date: 26/08/2023

Book No. :  
L.R. No. :  
Transport: :  
Through: :

Sr.	Particulars	HSN Code	Quantity	Rate	Dis. %	GST %	Amount												
1	ORDER NO.: 247 PANASONIC 20W LED BATTEN  <u>Tube Light Lead</u>	85395200	40.00	180.00	15.25	18.00	6,101.71												
			<b>40.00</b>	<b>Sub Total</b>			<b>6,101.71</b>												
Bank Details: <b>HDFC BANK</b> A/C No: 50200065554518 IFSC CODE: HDFC0000101 BRANCH: DR. YAGNIK ROAD							<b>Sub Total</b> 6,101.71 <b>SGST</b> 549.15 <b>CGST</b> 549.15												
<b>GST Summary</b> <table border="1"> <thead> <tr> <th>Taxable Amt</th> <th>SGST</th> <th>SGST AMT</th> <th>CGST</th> <th>CGST AMT</th> <th>Total GST</th> </tr> </thead> <tbody> <tr> <td>6101.71</td> <td>9.00</td> <td>549.15</td> <td>9.00</td> <td>549.15</td> <td>1098.30</td> </tr> </tbody> </table>							Taxable Amt	SGST	SGST AMT	CGST	CGST AMT	Total GST	6101.71	9.00	549.15	9.00	549.15	1098.30	<b>Round Off</b> -0.01 <b>Grand Total</b> <b>7,200.00</b>
Taxable Amt	SGST	SGST AMT	CGST	CGST AMT	Total GST														
6101.71	9.00	549.15	9.00	549.15	1098.30														
<b>Total:</b> 6101.71 549.15 549.15 1098.30							<b>Grand Total</b> <b>7,200.00</b>												

Rs. Seven thousand two hundred only.

GST No: 24ABFPC2693FZY  
TERMS:  
Subject to RAJKOT Jurisdiction.  
Payment 100% within 15 Days only.  
E. & O. E.

For, CHANDAN ELECTRIC CORPORATION  
Authorized Signatory

**PAID**  
A/c No: 50200065554518  
Ch. No. A-253  
Bank: 23/09/2023

*[Handwritten Signature]*

**Registrar  
Atmiya University  
Rajkot**







**ATMIYA UNIVERSITY**

NAAC – Cycle – 1  
AISHE: U-0967

Criterion- VII

IV&BP

KI 7.2

M 7.2.1

**CHANDAN ELECTRIC CORPORATION**

20, NEW JAGANATH, PLOT MARUTI COMPLEX, RAJKOT-360005  
Phone: 0281-2467900 Email : chandanele.corp@gmail.com

ORIGINAL

**DEBIT RETAIL INVOICE**

To, ATMIYA UNIVERSITY  
FACULTY OF SCIENCE  
KALAWAD ROAD.  
RAJKOT  
Ph. No:  
Party's GST No:

Invoice No: R 641 Date: 25/08/2023  
Book No.:  
L.R. No.:  
Transport:  
Through:

Sr.	Particulars	HSN Code	Quantity	Rate	Dis.%	GST%	Amount
1	ORDER NO.: 246 PANASONIC 20W LED BATTEN  <u>Tube Light Led</u>	85395200	30.00	180.00	15.25	18.00	4,576.50
			30.00	<b>Sub Total</b>			4,576.50

Bank Details: **HDFC BANK**  
A/C No: 5020065554518 IFSC CODE: HDFC0000101  
BRANCH: DR. YAGNIK ROAD

<b>GST Summary</b>	<b>Taxable Amt</b>	<b>SGST</b>	<b>SGST AMT</b>	<b>CGST</b>	<b>CGST AMT</b>	<b>Total GST</b>
GST @18.00	4576.50	9.00	411.89	9.00	411.89	823.78

Sub Total: 4,576.50  
SGST: 411.89  
CGST: 411.89  
Round Off: -0.28  
**Grand Total: 5,400.00**

Total : 4576.50 411.89 411.89 823.78

**Rs. Five thousand four hundred only.**

GST No: 24ABFPC2693F22Y For, CHANDAN ELECTRIC CORPORATION  
TERMS:  
Subject to RAJKOT Jurisdiction.  
Payment 100% within 15 Days only.  
E. & O. E.

Authorized Signatory

**PAID**  
A/c No. 5020065554518  
Bank: HDFC  
Date: 13-09-23

*[Handwritten Signature]*

**Registrar  
Atmiya University  
Rajkot**





**KKARA ELECTRICAL & ELECTRONICS**

NEAR MATUKI RESTAURANT,  
KALAWAD ROAD, RAJKOT MO NO - 9712709029, 8000056066

**Debit Memo** **TAX INVOICE** Original

M/s. : **ATMIYA UNIVERSITY**  
KALAWAD ROAD, NEAR WATER TANK,  
YOGIDHAM GURUKUL,  
**RAJKOT**  
Place of Supply : 24-Gujarat

Invoice No. : 211  
Date : 09/01/2024  
Transport :  
L.R. No. :  
L.R. Date : / /

SrNo	Product Name	HSN/SAC	Qty	Rate	GST %	Amount
1	150W FLOODLIGHT CW ( HEAVY )	9405	7.00	2850.00	18.00	19950.00

**PAID**

Axis 800464151042  
Ch. No. \_\_\_\_\_  
Bank, AXIS  
Date 24-01-24

**GSTIN No.:** 24AARFK8978N1Z5 **Sub Total** 19950.00

**Bank Name** : HDFC BANK  
**Bank A/c. No.** : 99999909048484  
**RTGS/IFSC Code** : HDFC0009405

**Total GST** : Three Thousand Five Hundred Ninety One Only

**Bill Amount** : Twenty Three Thousand Five Hundred Forty One Only

**Note** : Ref Po Number - Au/electrical/po/172/2023-24 Po Date - 21/12/2023

<b>Taxable Amount</b>	19950.00
Central Tax	9.00% 1795.50
State/UT Tax	9.00% 1795.50
<b>Grand Total</b>	<b>23,541.00</b>

**Terms & Condition :**

- Goods once sold will not be taken back.
- Interest @18% p.a. will be charged if payment is not made within due date.
- Our risk and responsibility ceases as soon as the goods leave our premises.
- "Subject to 'RAJKOT' Jurisdiction only. E.&O.E"

For, KKARA ELECTRICAL & ELECTRONICS

**Registrar**  
**Atmiya University**  
**Rajkot**





**ATMIYA UNIVERSITY**

**NAAC – Cycle – 1  
AISHE: U-0967**

**Criterion- VII**

**IV&BP**

**KI 7.2**

**M 7.2.1**

**Tax Invoice** (ORIGINAL FOR RECIPIENT)

<b>CHANDAN ELECTRIC SERVICE</b> "Sneh Ashish" New Jagnath, Rajkot - 360001 Contact : 9909905526/9429501677 E-Mail : chandaneleservice@yahoo.com GSTIN/UIN: 24ABJPC0071B1ZJ State Name : Gujarat, Code : 24		Invoice No. <b>CES/4460/23-24</b> Dated <b>26-Jan-24</b> Delivery Note <b>4598</b> Reference No. & Date. Other References	
Buyer (Bill to) <b>Atmiya University</b> FOET, Rajkot State Name : Gujarat, Code : 24 Contact : 9874563210		Buyer's Order No. Dated Dispatch Doc No. Delivery Note Date <b>10-Jan-24</b> Dispatched through Destination	

Sl No.	Description of Goods and Services	HSN/SAC	GST Rate	Quantity	Rate	per	Disc. %	Amount	
1	Order No:- 4598 Date 10-1-2024 Havells Trim Plus LED Panel Squire Light 12W White <i>Panel Light Led</i>	94051100	18 %	20 Nos	448.40	Nos	15.25 %	7,600.38	
								684.03	
								684.03	
	<i>Less Round Off</i>							<i>(-10.44)</i>	
<b>Total</b>								<b>20 Nos</b>	<b>₹ 8,968.00</b>

Prev Balance **80,533.00 Dr**  
 Bill Amount **8,968.00 Dr**  
 Net Balance **89,501.00 Dr**

Amount Chargeable (in words) **INR Eight Thousand Nine Hundred Sixty Eight Only**

Company's Bank Details  
 Bank Name : Hdfc Bank  
 A/c No. : 50200040487961  
 Branch & IFS Code : Dr.Yagnik Road & HDFC0000101

Declaration  
 We declare that this invoice shows the actual price of the goods described and that all particulars are true and correct.

for CHANDAN ELECTRIC SERVICE  
 Authorised Signatory

*Tds on purchase of goods = 91 = 6968/1 =*

*TDS D.I.T.O.N RS. 6968/1 =*

*6959/1 =*

**Registrar  
Atmiya University  
Rajkot**







**ATMIYA  
UNIVERSITY**

**NAAC – Cycle – 1  
AISHE: U-0967**

**Criterion- VII**

**IV&BP**

**KI 7.2**

**M 7.2.1**

**Tax Invoice** (ORIGINAL FOR RECIPIENT)

<b>CHANDAN ELECTRIC SERVICE</b> "Sneh Ashish" New Jagnath, Rajkot - 360001 Contact : 9909905526/9429501677 E-Mail : chandaneleservice@yahoo.com GSTIN/UIN: 24ABJPC0071B1ZJ State Name : Gujarat, Code : 24		Invoice No. <b>CES/164/24-25</b>	Dated <b>9-Apr-24</b>
Buyer (Bill to) <b>Atmiya University - FOS</b> Faculty of Science Rajkot State Name : Gujarat, Code : 24		Delivery Note <b>4793, 4944</b>	Reference No. & Date.
		Buyer's Order No.	Dated
		Dispatch Doc No.	Delivery Note Date <b>23-Jan-24, 31-Jan-24</b>
		Dispatched through	Destination

Sl No.	Description of Goods	HSN/SAC	Quantity	Rate	per	Disc. %	Amount
1	Order No.- 4793 Date 23-1-2024 <b>Halonix Sensar LED Lamp 10W</b> Motion Sensor	85395200	<b>15 Nos</b>	220.00	Nos		<b>3,300.00</b>
2	Order No.- 4944 Date 31-1-2024 <b>PVC Connector</b>	39269099	<b>20 Nos</b>	15.00	Nos		<b>300.00</b>
							<b>3,600.00</b>
C Gst							<b>324.00</b>
S Gst							<b>324.00</b>
Round Off							<b>324.00</b>
<b>Total</b>							<b>35 Nos</b>
							<b>₹ 4,248.00</b>

Prev Balance

Bill Amount **4,248.00 Dr**

Net Balance **4,248.00 Dr**

Amount Chargeable (in words)

**INR Four Thousand Two Hundred Forty Eight Only**

Taxable Value	CGST		SGST/UTGST		Total Tax Amount
	Rate	Amount	Rate	Amount	
3,600.00	9%	324.00	9%	324.00	648.00
<b>Total:</b>		<b>3,600.00</b>		<b>324.00</b>	<b>648.00</b>

Tax Amount (in words) : **INR Six Hundred Forty Eight Only**

Company's Bank Details  
 Bank Name : **Hdfc Bank**  
 A/c No. : **[REDACTED]**  
 Branch & IFS Code : **Dr.Yagnik Road & [REDACTED]**

Declaration  
 We declare that this invoice shows the actual price of the goods described and that all particulars are true and correct.

Authorized Signatory

This is a Computer Generated Invoice

**Registrar  
Atmiya University  
Rajkot**





**ATMIYA UNIVERSITY**

NAAC – Cycle – 1  
AISHE: U-0967

Criterion- VII

IV&BP

KI 7.2

M 7.2.1

**CHANDAN ELECTRIC CORPORATION**

20, NEW JAGANATH, PLOT MARUTI COMPLEX, RAJKOT-360005  
Phone: 0281-2467900 Email : chandanele.corp@gmail.com

DEBIT **RETAIL INVOICE** ORIGINAL

To, ATMIYA UNIVERSITY (FOS)

Invoice No: R 1244 Date: 22/02/2024

Book No. :  
L.R. No.:  
Transport:  
Through:

RAJKOT (Gujarat)  
Ph. No.:

Party's GST No:

Sr.	Particulars	HSN Code	Quantity	Rate	Dis-%	GST%	Amount
1	ANCH. 20W LED PATTI <u>Tube Light Led</u>	76042100	30.00	180.00	15.25	18.00	4,576.28
			<b>30.00</b>	<b>Sub Total</b>			<b>4,576.28</b>

**PAID**

Ch. No. AX15P00494224024

Bank A023

Date 29/02/24

Bank Details: **HDFC BANK**  
A/C No: 50200065554518 IFSC CODE: HDFC0000101  
BRANCH: DR. YAGNIK ROAD

GST Summary	Taxable Amt	SGST	SGST AMT	CGST	CGST AMT	Total GST
GST @18.00	4576.28	9.00	411.87	9.00	411.87	823.74
<b>Total :</b>	<b>4576.28</b>		<b>411.87</b>		<b>411.87</b>	<b>823.74</b>

Sub Total 4,576.28  
SGST 411.87  
CGST 411.87  
Round Off -0.02  
**Grand Total 5,400.00**

**Rs. Five thousand four hundred only.**

GST No:24ABFPC2693F2ZY  
TERMS:  
Subject to RAJKOT Jurisdiction.  
Payment 100% within 15 Days only.  
E. & O. E.

For, CHANDAN ELECTRIC CORPORATION  
  
Authorised Signatory

**Registrar  
Atmiya University  
Rajkot**





**ATMIYA  
UNIVERSITY**

**NAAC – Cycle – 1  
AISHE: U-0967**

**Criterion- VII**

**IV&BP**

**KI 7.2**

**M 7.2.1**

**CHANDAN ELECTRIC SERVICE**

"Sneh Ashish", 20 New Jagmath, Rajkot - 360001. M: 990 990 55 26 / 942 950 16 77  
Email: chandaneleservice@yahoo.com

GSTIN No : 24ABJPC0071B1ZJ PAN No : ABJPC0071B

<b>Debit Memo</b>		<b>Tax Invoice</b>		<b>Original</b>	
To, <b>Atmiya University</b>		Has Reverse Charges : No		Invoice No. <b>R-760</b> Invoice Dt. <b>25-01-2023</b>	
Rajkot		Invoice No. <b>R-760</b>		Invoice Dt. <b>25-01-2023</b>	
24-Gujarat		Outstanding Balance: <b>9,923.00</b>		Payment Should be made in 15 days.	
Mobile No : 9874563210					

Sr	HSN	Particular	Qty	Rate	Disc %	Taxable Amount	CGST %	Tax	SGST %	Tax
1	84145190	Order No: SC01-226 Date: 13-01-2023 Havells 200MM DX Ventilating Fan	1 pc	1,298.00		1,298.00	9.0	116.82	9.0	116.82
2	84145190	Havells 250MM DX Ventilating Fan	1 pc	1,386.00		1,386.00	9.0	124.74	9.0	124.74
3	94054090	Havells 12W Square White Trim Plus Led Light	5 pc	536.00		2,680.00	9.0	241.20	9.0	241.20

① Exhaust Fan  
③ panel led Light

PAID

Ch. No. **AXSP20364005112**

Bank **AXII**

Date **7-2-23**

Bank : HDFC BANK	Branch : Dr. Yagnik Road	Amount : 5,364.00
RTGS/IFSC : HDFC0000101	A/C : 50200040487961	SGST : 482.76
Amount in Words: Six Thousand Three Hundred Thirty Only		CGST : 482.76
		Rounding : 0.48
		<b>Grand Total 6,330.00</b>

**Terms & Conditions:**

- Interest 18% p.a. will be charged, if payment not made as per order's terms.
- Goods once sold will not be taken back.
- Guarantee & Warrantee are according to the manufacturer's terms and conditions.
- All Transactions are subject to Rajkot jurisdiction.
- E & OE.

**For, Chandan Electric Service**  
For: Chandan Electric Service.  
*(Signature)*  
Proprietor  
Authorised Signatory

Page 1 of 1

*(Signature)*

**Registrar  
Atmiya University  
Rajkot**







**ATMIYA UNIVERSITY**

NAAC – Cycle – 1  
AISHE: U-0967

Criterion- VII

IV&BP

KI 7.2

M 7.2.1

**REVA ELECTRICALS**

SANGANWA CHOWK RAJDEV STREET RAJKOT  
Phone: 2234278 2228916 99041 00075 Email: 93693 93694

**ORIGINAL**

**DEBIT TAX INVOICE**

To: **ATMIYA UNIVERSITY**  
YOGIDHAM GURUKUL  
KALAWAD ROAD  
**RAJKOT (Gujarat)**  
Ph. No:  
Party's GST No:

Invoice No: 110089 Date: 10/12/22  
Challan No. : 20074 Date : 10/12/22  
Transport :  
L.R.No. : Date : / /  
Vehicle No. : No. of Case :

**Payment must be made within days.**

Sr	Particulars	HSN	Rate	Qty	Amount	Tax	Amount
1	FAN 16" WALL FAN <i>model - swing</i>	8414	4.00	15.254	2299.00	18.00	7793.24
					<b>Sub Total</b>		<b>7,793.24</b>

**PAID**

Ch. No. *DNSPO048857956*  
Bank *PNB*  
Date *29-12-22*

**closing bal : 0.00**

**USHA TOLL FREE NO 1800 1033 111**

GST Summary	Taxable Amnt	SGST	SGST AMT	CGST	CGST AMT	Total GST
GST @18.00	7793.24	8.00	701.39	8.00	701.39	1402.78
<b>Total :</b>	<b>7793.24</b>		<b>701.39</b>		<b>701.39</b>	<b>1402.78</b>

Sub Total **7,793.24**  
SGST 701.39  
CGST 701.39  
Round Off -0.02  
**Grand Total 9,196.00**

**RS. Nine thousand one hundred ninety six only.**

GST No: 24ACYPP0074B1ZM  
Bank Details: **HDFC BANK LTD,**  
A/C No: 50200013922771 IFSC CODE: HDFC0000101  
BRANCH: Dr YAGNIK ROAD BRANCH, RAJKOT

**For, REVA ELECTRICALS**  
  
Authorised Signatory

**TERMS & CONDITIONS:**  
1. GOODS ONCE SOLD WILL NOT BE TAKEN BACK.  
2. SUBJECT TO RAJKOT JURISDICTION. E.&O.E.

**Registrar  
Atmiya University  
Rajkot**





**ATMIYA  
UNIVERSITY**

**NAAC – Cycle – 1  
AISHE: U-0967**

**Criterion- VII**

**IV&BP**

**KI 7.2**

**M 7.2.1**

CHANDAN ELECTRIC CORPORATION							
20, NEW JAGANATH, MARUTI COMPLEX, RAJKOT-360001. Phone: 0281-2467900 Email : chandanele.corp@gmail.com							
EBIT				RETAIL INVOICE		ORIGINAL	
<b>To, ATMIYA UNIVERSITY FACULTY</b> OF ENGINEERING & TECHNOLOGY  <b>RAJKOT (Gujarat)</b> Ph. No: Party's GST No:				<b>Invoice No: R 28</b> Date: 08/04/2022 Book No.: L.R. No.: Transport: Through:			
Sr.	Particulars	HSN Code	Quantity	Rate	Dis.%	GST%	Amount
	ORDER NO.: 427						
1	ANCH. ROMA PLATE 8-MODU TRESA } plate electric	8538	20.00	276.00	52.00	18.00	2,649.60
2	ANCH. ROMA PLATE 4 MODU. TRESA	8538	5.00	156.00	52.00	18.00	374.40
3	ANCH. ROMA PLATE 3-MODU TRESA	8538	30.00	135.00	52.00	18.00	1,944.00
4	ANCH. ROMA 10A 1-WAY SWITCH	8536	40.00	70.00	55.00	18.00	1,260.00
5	ANCH. ROMA 20-A 1-WAY SWITCH	8536	30.00	157.00	52.00	18.00	2,260.80
6	ANCH. ROMA 10A SOCKET 2-IN-1	8536	60.00	153.00	52.00	18.00	4,406.40
7	ANCH. ROMA 20-A SOCKET HEAVY DUTY	8536	30.00	251.00	52.00	18.00	3,614.40
8	ANCH. ROMA 2-MO. STEP FAN REGULATR	8536	10.00	458.00	52.00	18.00	2,198.40
9	PANASONIC 20W LED BATTEN - Tube Light	405	20.00	180.00	10.71	12.00	3,214.44
			<b>245.00</b>	<b>Sub Total</b>			<b>21,922.44</b>
<b>PAID</b> Ch. No. _____ Bank _____ Date: 6/5/22							
<b>Bank Details: HDFC BANK</b> A/C No: 50200065554518 IFSC CODE: HDFC0000101 BRANCH: DR. YAGNIK ROAD				<b>Sub Total</b> 21,922.44 <b>SGST</b> 1,876.59 <b>CGST</b> 1,876.59			
<b>GST Summary</b>	<b>Taxable Amt</b>	<b>SGST</b>	<b>SGST AMT</b>	<b>CGST</b>	<b>CGST AMT</b>	<b>Total GST</b>	
GST @18.00	18708.00	9.00	1683.72	9.00	1683.72	3367.44	
GST @12.00	3214.44	6.00	192.86	6.00	192.86	385.73	
<b>Total :</b>						<b>3753.18</b>	
				<b>Sub Total</b>		<b>25,676.00</b>	
				<b>Round Off</b>		0.38	
				<b>Grand Total</b>		<b>25,676.00</b>	
<b>Rs. Twenty five thousand six hundred seventy six only.</b> <b>GST No:24ABFPC2693F2ZY</b> <b>TERMS:</b> Subject to RAJKOT Jurisdiction. Payment 100% within 15 Days only. E. & O. E.							
				<b>Eor, CHANDAN ELECTRIC CORPORATION</b>  Authorized Signatory			



**Registrar  
Atmiya University  
Rajkot**





**ATMIYA  
UNIVERSITY**

**NAAC – Cycle – 1  
AISHE: U-0967**

**Criterion- VII**

**IV&BP**

**KI 7.2**

**M 7.2.1**

**REVA ELECTRICALS**

SANGANWA CHOWK RAJDEV STREET RAJKOT  
Phone: 2234278 2228916 99041 00075 Email: 93693 93694

**DEBIT TAX INVOICE ORIGINAL**

**To, ATMIYA UNIVERSITY FACULTY OF**  
BUSINESS & COMMERCE  
KALAWAD ROAD  
**RAJKOT (Gujarat)**  
Ph. No:  
Party's GST No:

**Invoice No. TG 265** Date: 15/07/2022  
Challan No. : 19457 Date : 15/07/22  
Transport :  
L.R.No. : Date : / /  
Vehicle No. : No.of Case :

**Payment must be made within days.**

Sr.	Particulars	HSN Code	Quantity	Disc.	Rate	GST%	Amount	
1	LED 18 PL 4PIN <i>Led PL wipro</i>	94051090	20.00	10.715	390.00	12.00	6964.23	
							<b>Sub Total</b>	<b>6,964.23</b>
							<b>WIPRO</b>	
<b>closing bal :0.00</b>								
<b>USHA TOLL FREE NO 1800 1033 111</b>								
<b>GST Summary</b>								
	<b>Taxable Amt</b>	<b>SGST</b>	<b>SGST AMT</b>	<b>CGST</b>	<b>CGST AMT</b>	<b>Total GST</b>		
	GST @12.00	6964.23	8.00	417.85	8.00	417.85	835.70	
<b>Total :</b>								
	6964.23		417.85		417.85	835.70	<b>Grand Total 7,800.00</b>	

**PAID**  
AXIS BANK 305291044  
Date 21/7/22

**For, REVA ELECTRICALS**  
**REVA ELECTRICALS**  
Proprietor  
Authorized Signatory

**TERMS & CONDITIONS:**  
1. GOODS ONCE SOLD WILL NOT BE TAKEN BACK.  
2. SUBJECT TO RAJKOT JURISDICTION. E. & O.E.

*[Handwritten Signature]*

**Registrar  
Atmiya University  
Rajkot**







**ATMIYA  
UNIVERSITY**

NAAC – Cycle – 1  
AISHE: U-0967

Criterion- VII

IV&BP

KI 7.2

M 7.2.1

**CHANDAN ELECTRIC CORPORATION**

20, NEW JAGANATH, PLOT MARUTI COMPLEX, RAJKOT-360005  
Phone: 0281-2467900 Email : chandanele.corp@gmail.com

**RETAIL INVOICE** ORIGINAL

**To, ATMIYA UNIVERSITY FACULTY OF**  
SCIENCE  
"YOGIDHAM-GURUKUL"  
**RAJKOT (Gujarat)**  
Ph. No: 9909089782  
Party's GST No:

**Invoice No: R 355** Date: 29/06/2022  
Book No.:  
L.R. No.:  
Transport:  
Through:

Sr.	Particulars	HSN Code	Quantity	Rate	Dis. %	GST%	Amount
1	ORDER NO.: 798 PANASONIC 20W LED BATTEN  Tube Light Led	9405	20.00	180.00	10.71	12.00	3,214.44
			<b>20.00</b>	<b>Sub Total</b>			<b>3,214.44</b>

**PAID**  
Ch. No. \_\_\_\_\_  
Date: 12/7/22

Bank Details: **HDFC BANK**  
A/C No: 50200065554518 IFSC CODE: HDFC0000101  
BRANCH: DR. YAGNIK ROAD

<b>Sub Total</b>	<b>3,214.44</b>
SGST	192.87
CGST	192.87
Round Off	-0.18
<b>Grand Total</b>	<b>3,600.00</b>

GST Summary	Taxable Amt	SGST	SGST AMT	CGST	CGST AMT	Total GST
GST @12.00	3214.44	6.00	192.87	6.00	192.87	385.74
<b>Total :</b>	<b>3214.44</b>		<b>192.87</b>		<b>192.87</b>	<b>385.74</b>

**Rs. Three thousand six hundred only.**

GST No: 24ABFPC2693F2ZY  
TERMS:  
Subject to RAJKOT Jurisdiction.  
Payment 100% within 15 Days only.  
E. & O. E.

**For, CHANDAN ELECTRIC CORPORATION**  
Authorized Signatory

**Registrar  
Atmiya University  
Rajkot**





**ATMIYA UNIVERSITY**

NAAC – Cycle – 1  
AISHE: U-0967

Criterion- VII

IV&BP

KI 7.2

M 7.2.1

**CHANDAN ELECTRIC CORPORATION**

20, NEW JAGANATH, PLOT MARUTI COMPLEX, RAJKOT-360005  
Phone: 0281-2467900 Email : chandanele.corp@gmail.com

ORIGINAL

**DEBIT RETAIL INVOICE**

To, **ATMIYA UNIVERSITY (FOBC)** Invoice No: **R 1104** Date: **13/01/2023**

KALAWAD ROAD. Book No. :  
RAJKOT (Gujarat) L.R. No.: :  
Ph. No: Transport: :  
Party's GST No: Through: :

Sr.	Particulars	HSN Code	Quantity	Rate	Dis.%	GST%	Amount
1	ANCH. 9W LED BULB <i>Lead Lamp</i>	94059900	12.00	75.00	15.25	18.00	762.71
2	ANCH. LED 5W BULB	8539	12.00	75.00	15.25	18.00	762.71
3	ANCH. PENTA 6A 2-PIN SOCKET <i>Elect.</i>	84149030	20.00	36.00	47.00	18.00	381.60
			<b>44.00</b>	<b>Sub Total</b>			<b>1,907.02</b>

*Rate with tax high  
2) RS-2=00 E-Pun 10/2022*

**PAID**

Ch. No: *AXIS0039793375*

Dank: *AXIS*

Date: *30/01/23*

Bank Details: **HDFC BANK**  
A/C No: 50200065554518 IFSC CODE: HDFC0000101  
BRANCH: DR. YAGNIK ROAD

<b>GST Summary</b>	<b>Taxable Amnt</b>	<b>SGST</b>	<b>SGST AMT</b>	<b>CGST</b>	<b>CGST AMT</b>	<b>Total GST</b>
GST @18.00	1907.02	9.00	171.63	9.00	171.63	343.26
<b>Total :</b>	<b>1907.02</b>		<b>171.63</b>		<b>171.63</b>	<b>343.26</b>

Sub Total: 1,907.02  
SGST: 171.63  
CGST: 171.63  
Round Off: 0.28  
**Grand Total: 2,250.00**

**Rs. Two thousand two hundred fifty only.**

GST No: 24ABFPC2693F2ZY  
TERMS:  
Subject to RAJKOT Jurisdiction.  
Payment: 100% within 15 Days only.  
E. & O. E.

For, **CHANDAN ELECTRIC CORPORATION**  
Authorized Signatory

**Registrar**  
**Atmiya University**  
**Rajkot**





**ATMIYA  
UNIVERSITY**

**NAAC – Cycle – 1  
AISHE: U-0967**

**Criterion- VII**

**IV&BP**

**KI 7.2**

**M 7.2.1**

**CHANDAN ELECTRIC SERVICE**

"Sneh Ashish", 20 New Jagnath, Rajkot - 360001. M: 990 990 55 26 / 942.950 16 77  
Email: chandaneleservice@yahoo.com

GSTIN No : 24ABJPC0071B1ZJ      PAN No : ABJPC0071B

Debit Memo		Tax Invoice				Original				
<b>To, Atmiya University</b> Rajkot 24-Gujarat Mobile No : 9874563210					Has Reverse Charges <input checked="" type="checkbox"/> No <b>Invoice No. :</b> R-69 <b>Invoice Dt. :</b> 28-04-2022 <b>Outstanding Balance: 19,175.00</b> Payment Should be make in 15 days.					
Sr	HSN	Particular	Qty	Rate	Disc %	Taxable Amount	CGST %	SGST %	Tax	
1	76042100	Order No: SC04-221      Date: 22-04-2022 DG 17x8 Trim DG-A001 Aluminium Profile  <i>Aluminium Profile</i>	250 mtr	65.00		16,250.00	9.0	9.0	1,462.50	
<div style="border: 1px solid black; padding: 5px; display: inline-block;"> <b>PAID</b>            AXIS 000289674299            Ch. No.            Bank: <u>AXIS</u>            Date: <u>20/5/22</u> </div>										
Bank : HDFC BANK      Branch : Dr. Yagnik Road RTGS/IFSC : HDFC0000101      A/C : 50200040487961							Amount		16,250.00	
							SGST		1,462.50	
							CGST		1,462.50	
Amount in Words: Nineteen Thousand One Hundred Seventy Five Only										
							<b>Grand Total</b>		<b>19,175.00</b>	
<b>Terms &amp; Conditions:</b> 1. Interest 18% p.a. will be charged, if payment not made as per order's terms. 2. Goods once sold will not be taken back. 3. Guarantee & Warrantee are according to the manufacturer's terms and conditions. 4. All Transactions are subject to Rajkot jurisdiction. 5. E & OE.							For, Chandan Electric Service, <i>Sh.</i> <b>Proprietor.</b> Authorised Signatory			

Page 1 of 1

**Registrar  
Atmiya University  
Rajkot**







**ATMIYA  
UNIVERSITY**

**NAAC – Cycle – 1  
AISHE: U-0967**

**Criterion- VII**

**IV&BP**

**KI 7.2**

**M 7.2.1**

**CHANDAN ELECTRIC SERVICE**

"Sneh Ashish", 20 New Jagnath, Rajkot - 360001. M: 990 990 55 26 / 942 950 16 77  
Email: chandaneleservice@yahoo.com

GSTIN No : 24ABJPC0071B1ZJ PAN No : ABJPC0071B

Debit Memo		Tax Invoice				Original				
To, Atmiya University Rajkot 24-Gujarat Mobile No : 9874563210		Has Reverse Charges : No Invoice No. : R-98 Invoice Dt. : 10-05-2022 Outstanding Balance: 53,690.00 Payment Should be made in 15 days.								
Sr	HSN	Particular	Qty	Rate	Disc %	Taxable Amount	CGST %	SGST %	Tax	
1	76042100	Order No: SC04-292 Date: 29-04-2022 DG 17x8 DG-A002 Aluminium Profile	450 mtr	65.00		29,250.00	9.0	9.0	2,632.50	
<div style="border: 1px solid black; padding: 5px; width: fit-content; margin: 0 auto;"> <p style="text-align: center;"><b>PAID</b></p> <p style="text-align: center;">A/c No. 200290482324</p> <p style="text-align: center;">Ch. No.</p> <p style="text-align: center;">Bank. A/S</p> <p style="text-align: center;">Date 25/5/22</p> </div>										
Bank : HDFC BANK Branch : Dr. Yagnik Road RTGS/IFSC : HDFC0000101 A/C : 50200040487961							Amount		29,250.00	
Amount in Words: Thirty Four Thousand Five Hundred Fifteen Only							SGST		2,632.50	
							CGST		2,632.50	
							<b>Grand Total</b>		<b>34,515.00</b>	
<b>Terms &amp; Conditions:</b> 1. Interest 18% p.a. will be charged, if payment not made as per order's terms. 2. Goods once sold will not be taken back. 3. Guarantee & Warrantee are according to the manufacturer's terms and conditions. 4. All Transactions are subject to Rajkot jurisdiction. 5. E & OE.							<b>For, Chandan Electric Service</b> <i>For Chandan Electric Service</i> Authorised Signatory			

**Registrar  
Atmiya University  
Rajkot**





**ATMIYA  
UNIVERSITY**

**NAAC – Cycle – 1  
AISHE: U-0967**

**Criterion- VII**

**IV&BP**

**KI 7.2**

**M 7.2.1**

**CHANDAN ELECTRIC SERVICE**

"Sneh Ashish", 20 New Jagnath, Rajkot - 360001. M: 990 990 55 26 / 942 950 16 77  
Email: chandaneleservice@yahoo.com

GSTIN No : 24ABJPC0071B1ZJ PAN No : ABJPC0071B

Debit Memo		Tax Invoice					Original				
To, Atmiya University Rajkot 24-Gujarat Mobile No : 9874563210		Has Reverse Charges : No					Invoice No. R-118 Invoice Dt : 17-05-2022				
		Outstanding Balance: 76,700.00 Payment Should be made in 15 days.									
Sr	HSN	Particular	Qty	Rate	Disc %	Taxable Amount	CGST %	Tax	SGST %	Tax	
1	76042100	Order No: SC05-93 Date: 11-05-2022 DG 17x8 DG-A002 Aluminium Profile	150 mtr	65.00		9,750.00	9.0	877.50	9.0	877.50	
2	76042100	Order No: SC05-105 Date: 13-05-2022 DG 17x8 DG-A002 Aluminium Profile	150 mtr	65.00		9,750.00	9.0	877.50	9.0	877.50	
							Amount		19,500.00		
							SGST		1,755.00		
							CGST		1,755.00		
Bank : HDFC BANK Branch : Dr. Yagnik Road							Amount				
RTGS/IFSC : HDFC0000101 A/C : 50200040487961							SGST				
Amount in Words: Twenty Three Thousand Ten Only							CGST				
							<b>Grand Total ₹ 23,010.00</b>				
Terms & Conditions:							For, Chandan Electric Service				
1. Interest 18% p.a. will be charged, if payment not made as per order's terms.							For Chandan Electric Service.				
2. Goods once sold will not be taken back.							<i>[Signature]</i>				
3. Guarantee & Warrantee are according to the manufacturer's terms and conditions.							Proprietor				
4. All Transactions are subject to Rajkot jurisdiction.							Authorised Signatory				
5. E & OE.											

**PAID**

Ch. No. \_\_\_\_\_

Bank \_\_\_\_\_

Date: 17/05/22

Page 1 of 1

*[Signature]*

**Registrar  
Atmiya University  
Rajkot**





**ATMIYA  
UNIVERSITY**

**NAAC – Cycle – 1  
AISHE: U-0967**

**Criterion- VII**

**IV&BP**

**KI 7.2**

**M 7.2.1**

**CHANDAN ELECTRIC SERVICE**

"Sneh Ashish", 20 New Jagnath, Rajkot - 360001. M: 990 990 55 26 / 942 950 16 77  
Email: chandaneleservice@yahoo.com

GSTIN No : 24ABJPC0071B1ZJ PAN No : ABJPC0071B

Debit Memo		Tax Invoice				Original				
<b>To, Atmiya University</b> Rajkot 24-Gujarat Mobile No : 9874563210					Has Reverse Charges : No <b>Invoice No. : R-419</b> <b>Invoice Dt. : 10-09-2022</b> <b>Outstanding Balance: 91,104.00</b> Payment Should be made in 15 days.					
Sr	HSN	Particular	Qty	Rate	Disc %	Taxable Amount	CGST %	SGST %	Tax	
1	94054090	Order No: SC08-240    Date: 25-08-2022 Havells 12W Square White Trim Plus Led Light  <i>Panel Light</i>  <i>Rate with tax high</i> <i>RS.-0.28 L.PM 23/8/22</i>	10 pc	454.24		4,542.37	9.0	9.0	408.81	
<b>PAID</b> Ch. No. <i>AXISP@ 322653126</i> Bank <i>AXIS</i> Date <i>27/9/22</i>										
Bank : HDFC BANK    Branch : Dr. Yagnik Road RTGS/IFSC : HDFC0000101    A/C : 50200040487961							Amount 4,542.37 SGST 408.81 CGST 408.81 Rounding 0.01			
Amount in Words: Five Thousand Three Hundred Sixty Only							<b>Grand Total 5,360.00</b>			
<b>Terms &amp; Conditions:</b> 1. Interest 18% p.a. will be charged, if payment not made as per order's terms. 2. Goods once sold will not be taken back. 3. Guarantee & Warrantee are according to the manufacturer's terms and conditions. 4. All Transactions are subject to Rajkot jurisdiction. 5. E & OE.							<b>For, Chandan Electric Service</b> <i>Proprietor</i> <b>Proprietor</b> Authorised Signatory			

Page 1 of 1

*[Handwritten Signature]*

**Registrar  
Atmiya University  
Rajkot**







**CHANDAN ELECTRIC SERVICE**

"Sneh Ashish", 20 New Jagnath, Rajkot - 360001. M: 990 990 55 26 / 942 950 16 77  
Email: chandaneleservice@yahoo.com

GSTIN No : 24ABJPC0071B1ZJ PAN No : ABJPC0071B

**Debit Memo Tax Invoice** Ori

To: **Atmiya University-Faculty of Business & Commerce**  
Rajkot  
24-Gujarat

Has Reverse Charge: No  
Invoice No. **R-750** Invoice Dt: **24-01-**  
**Outstanding Balance: 36,369.00**  
Payment Should be make in 15 days.

Sr	HSN	Particular	Qty	Rate	Disc %	Taxable Amount	CGST %	SGST %
1	94054090	AK 24W Street Light	7 pc	724.58		5,072.03	9.0	9.0
2	94054090	AK 50W Street Light	2 pc	974.58		1,949.15	9.0	9.0

Order No: SC12-170 Date: 10-12-2022

**LID**

Ch. No. **AMS/00359837360**

Bank **Axis**

Date **22/01/2023**

Bank : HDFC BANK Branch : Dr. Yagnik Road  
RTGS/IFSC : HDFC0000101 A/C : 50200040487961

Amount in Words: Eight Thousand Two Hundred Eighty Five Only

Amount	7,0
SGST	6:
CGST	6:
Rounding	
<b>Grand Total</b>	<b>8,28</b>

**For, Chandan Electric Ser**  
*For Chandan Electric Servi*  
Authorized Sign:

Terms & Conditions:  
1. Interest 18% p.a. will be charged, if payment not made as per order's terms.  
2. Goods once sold will not be taken back.  
3. Guarantee & Warrantee are according to the manufacturer's terms and conditions.  
4. All Transactions are subject to Rajkot jurisdiction.  
5. E & OE.

Page

**Registrar  
Atmiya University  
Rajkot**





**ATMIYA UNIVERSITY**

**NAAC – Cycle – 1  
AISHE: U-0967**

**Criterion- VII**

**IV&BP**

**KI 7.2**

**M 7.2.1**

**JIGNESH ELECTRIC STORES**

1 KOTAK STREET, CLOSE STREET, SANGANVA CHOWK RAJKOT-360001  
Phone: 9904100075 Email: jignesh\_ele\_stores@vahoo.co.in

**TAX INVOICE ORIGINAL**

**To, ATMIYA UNI.FACULTY OF SCIENCE**  
KALAWAD ROAD  
**RAJKOT (Gujarat)**  
Ph. No:  
Party's GST No:

Invoice No: G 350 Date: 13/06/2022  
Challan No. : 42436 Date :11/06/22  
Transport :  
L.R.No. : Date : / /  
Vehicle No. : No.of Case : 0.00

**Payment must be made within days.**

Sr	Particulars	HSN Code	Quantity	Disc.	Rate	GST%	Amount
1	LED PANEL 12W <i>Panel Light Led Great white</i>	9405	1.00	10.715	375.00	12.00	334.82
					<b>Sub Total</b>		<b>334.82</b>
<b>CLOSING BAL :0.00</b>							
<b>USHA TOLL FREE NO 1800 1033 111</b>							
<b>GST Summary</b>							
	<b>Taxable Amnt</b>	<b>SGST</b>	<b>SGST AMT</b>	<b>CGST</b>	<b>CGST AMT</b>	<b>Total GST</b>	
	334.82	6.00	20.09	6.00	20.09	40.18	
<b>Total :</b>							
	334.82		20.09		20.09	40.18	
<b>Grand Total</b>							<b>375.00</b>

**PAID**  
Ch. No. 30344 1116  
Date: 13/7/22

**For, JIGNESH ELECTRIC STORE**  
K.B. Pujara  
Authorised Signatory

**TERMS & CONDITIONS:**  
1. GOODS ONCE SOLD WILL NOT BE TAKEN BACK.  
2. SUBJECT TO RAJKOT JURISDICTION: E.&O.E.

*[Handwritten Signature]*

**Registrar  
Atmiya University  
Rajkot**





**ATMIYA UNIVERSITY**

**NAAC – Cycle – 1  
AISHE: U-0967**

**Criterion- VII**

**IV&BP**

**KI 7.2**

**M 7.2.1**

**CHANDAN ELECTRIC SERVICE**

"Sneh Ashish", 20 New Jagnath, Rajkot - 360001. M: 990 990 55 26 / 942 950 16 77

Email: chandaneleservice@yahoo.com

GSTIN No : 24ABJPC0071B1ZJ

PAN No : ABJPC0071B

Debit Memo		Tax Invoice				Original				
To, Atmiya University-Faculty of Science					Has Reverse Charges: No					
Rajkot					Invoice No. : R-227 Invoice Dt. : 27-06-2022					
24-Gujarat					Outstanding Balance: 19,997.00					
					Payment Should be made in 15 days.					
Sr	HSN	Particular	Qty	Rate	Disc %	Taxable Amount	CGST %	Tax	SGST %	Tax
1	84145130	Order No: SC06-228 Date: 24-06-2022 Havells 400MM Swing Pedestal Fan	5 pc	4,045.00	40*	12,135.00	9.0	1,092.15	9.0	1,092.15
2	84145190	Havells 230MM DSP Ventilating Fan	2 pc	2,105.00	40	2,526.00	9.0	227.34	9.0	227.34
3	84145120	Havells 900MM SS390 Metallic Ceiling Fan	1 pc	3,810.00	40	2,286.00	9.0	205.74	9.0	205.74
		① Fan ② Exhaust fan								
<div style="border: 1px solid black; padding: 5px; display: inline-block;"> <b>PAID</b>            Ch. No. AXISP00304818015            Bank AXIS            Date 19/7/22         </div>										
Bank : HDFC BANK Branch : Dr. Yagnik Road						Amount 16,947.00				
RTGS/IFSC : HDFC0000101 A/C : 50200040487961						SGST 1,525.23				
Amount in Words: Nineteen Thousand Nine Hundred Ninety Seven Only						CGST 1,525.23				
						Rounding 0.46				
PO No:AU FoS/Fan/PO/39B-2022-23 Dt.:24-06-22						<b>Grand Total 19,997.00</b>				
<b>Terms &amp; Conditions:</b> 1. Interest 18% p.a. will be charged, if payment not made as per order's terms. 2. Goods once sold will not be taken back. 3. Guarantee & Warrantee are according to the manufacturer's terms and conditions. 4. All Transactions are subject to Rajkot jurisdiction. 5. E & OE.						<b>For, Chandan Electric Service</b> <b>For Chandan Electric Service.</b>  <b>Proprietor</b> Authorised Signatory				

Page 1 of 1

**Registrar  
Atmiya University  
Rajkot**







**ATMIYA  
UNIVERSITY**

**NAAC – Cycle – 1  
AISHE: U-0967**

**Criterion- VII**

**IV&BP**

**KI 7.2**

**M 7.2.1**

**REVA ELECTRICALS**

SANGANWA CHOWK RAJDEV STREET RAJKOT  
Phone: 2234278 2228916 99041 00075 Email: 93693 93694

**DEBIT TAX INVOICE ORIGINAL**

**To, ATMIYA UNIVERSITY FACULTY OF**  
BUSINESS & COMMERCE  
KALAWAD ROAD  
**RAJKOT (Gujarat)**  
Ph. No:  
Party's GST No:

Invoice No: 761519 Date: 06/12/2021  
Challan No. : 18699 Date : 04/12/21  
Transport :  
L.R.No. : Date : / /  
Vehicle No. : No. of Case :

**Payment must be made within days.**

Sr.	Particulars	HSN Code	Quantity	DISC	Rate	GST%	Amount
1	LED PANEL 18W <u>Lecl PL - Wipro</u>	94051090	20.00	10.715	380.00	12.00	6785.66
2	LED PANEL 18W	94051090	9.00		0.00	12.00	
3	LED T-5 10W <u>Tube Light Lecl</u>	94051090	5.00	10.715	180.00	12.00	803.57
	92						
				<b>34.00</b>	<b>Sub Total</b>		<b>7,589.23</b>
<b>closing bal : 0.00</b>							
<b>USHA TOLL FREE NO 1800 1033 111</b>							
						<b>Sub Total</b>	<b>7,589.23</b>
						SGST	455.35
						CGST	455.35
						Round Off	0.07
						<b>Grand Total</b>	<b>8,500.00</b>
<b>Total :</b>							
	7589.23		455.35		455.35	910.70	

**Rs. Eight thousand five hundred only.**

GST No: 24ACYPP0074B12M  
Bank Details: **HDFC BANK LTD,**  
A/C No: 50200013922771 IFSC CODE: HDFC0000101  
BRANCH: Dr YAGNIK ROAD BRANCH, RAJKOT

**For, REVA ELECTRICALS**  
Reva Electricals  
hitec  
Authorised Signatory

**TERMS & CONDITIONS:**  
1. GOODS ONCE SOLD WILL NOT BE TAKEN BACK.  
2. SUBJECT TO RAJKOT JURISDICTION. E & O.E.

**Registrar  
Atmiya University  
Rajkot**





**ATMIYA  
UNIVERSITY**

**NAAC – Cycle – 1  
AISHE: U-0967**

**Criterion- VII**

**IV&BP**

**KI 7.2**

**M 7.2.1**

**CHANDAN ELECTRIC CORPORATION**

20, NEW JAGANATH, MARUTI COMPLEX, RAJKOT-360001.  
Phone: 0281-2467900 Email : chandanele.corp@gmail.com

**DEBIT RETAIL INVOICE ORIGINAL**

**To, K.K MEHTA HOSTEL**  
KALAWAD ROAD.  
**RAJKOT 360004 (Gujarat)**  
Ph. No:  
Party's GST No:

**Invoice No: R 712** Date: 25/11/2021  
Book No. :  
L.R. No.:  
Transport:  
Through:

Sr.	Particulars	HSN Code	Quantity	*Rate	Dis.%	GST%	Amount
1	ORDER NO.: 099 PANASONIC 20W LED BATTEN <u>Tube Light Led</u>	9405	20.00	180.00	10.71	12.00	3,214.44
			<b>20.00</b>	<b>Sub Total</b>			<b>3,214.44</b>

Bank Details: **BANK OF BARODA**  
A/C No: 10600400005383 IFSC CODE: BARB0DBRACE  
BRANCH: ACE COURSE BRANCH, RAJKOT.

GST Summary	Taxable Amt	SGST	SGST AMT	CGST	CGST AMT	Total GST
GST @12.00	3214.44	6.00	192.87	6.00	192.87	385.74
<b>Total :</b>	<b>3214.44</b>		<b>192.87</b>		<b>192.87</b>	<b>385.74</b>

Sub Total: 3,214.44  
SGST: 192.87  
CGST: 192.87  
Round Off: -0.18  
**Grand Total: 3,600.00**

**Rs. Three thousand six hundred only.**

GST No: 24ABFPC2693F22Y  
TERMS:  
Subject to RAJKOT Jurisdiction.  
Payment 100% within 15 Days only.  
E. & O. E.

**PAID**  
Ch. No. 2426624  
Bank: **AXIS**  
14/11/21

**For, CHANDAN ELECTRIC CORPORATION**

**Registrar  
Atmiya University  
Rajkot**





**ATMIYA  
UNIVERSITY**

**NAAC – Cycle – 1  
AISHE: U-0967**

**Criterion- VII**

**IV&BP**

**KI 7.2**

**M 7.2.1**

**CHANDAN ELECTRIC CORPORATION**

20, NEW JAGANATH, MARUTI COMPLEX, RAJKOT-360001.  
Phone: 0281-2467900 Email : chandanele.corp@gmail.com

**DEBIT RETAIL INVOICE ORIGINAL**

**To, ATMIYA UNIVERSITY**  
FACULTY OF SCIENCE  
KALAWAD ROAD.  
**RAJKOT**  
Ph. No:  
Party's GST No:

**Invoice No: R 711** Date: 25/11/2021  
Book No. :  
L.R. No.: :  
Transport: :  
Through: :

Sr	Particulars	HSN Code	Quantity	Rate	Dis. %	GST%	Amount
1	ORDER NO.: 097 PANASONIC 20W LED BATTEN  <i>Tube Light Led</i>	9405	40.00	180.00	10.71	12.00	6,428.88
			<b>40.00</b>	<b>Sub Total</b>			<b>6,428.88</b>

Bank Details: **BANK OF BARODA**  
A/C No: 18800400005383 IFSC CODE: BARB0DBRACE  
BRANCH: RACE COURSE BRANCH, RAJKOT.

<b>Sub Total</b>							<b>6,428.88</b>
SGST							385.73
CGST							385.73
<b>Round Off</b>							-0.34
<b>Grand Total</b>							<b>7,200.00</b>

GST Summary	Taxable Amnt	SGST	CGST AMT	CGST	CGST AMT	Total GST
GST @12.00	6428.88	6.00	335.73	6.00	385.73	771.46
<b>Total :</b>	<b>6428.88</b>		<b>385.73</b>		<b>385.73</b>	<b>771.46</b>

**Rs. Seven thousand two hundred only.**

**GST No:24ABFPC2693F2ZY**  
**TERMS:**  
Subject to RAJKOT Jurisdiction.  
Payment 100% within 15 Days only  
E. & O. E.

**For, CHANDAN ELECTRIC CORPORATION**

Authorized Signatory

*[Handwritten Signature]*

**Registrar  
Atmiya University  
Rajkot**







**ATMIYA UNIVERSITY**

NAAC – Cycle – 1  
AISHE: U-0967

Criterion- VII

IV&BP

KI 7.2

M 7.2.1

**JIGNESH ELECTRIC STORES**

1 KOTAK STREET, CLOSE STREET, SANGANVA CHOWK RAJKOT-360001  
Phone: 9904100075 Email: jignesh\_ele\_stores@yahoo.co.in

**DEBIT TAX INVOICE ORIGINAL**

To, **ATMIYA UNIVERSITY**  
ATMIYA COLLEGE KALAWAD ROAD  
RAJKOT (Gujarat)  
Ph. No: \_\_\_\_\_  
Party's GST No: \_\_\_\_\_

Invoice No: **TG 632** Date: **20/11/2021**  
Challan No. : 41466 Date : 20/11/21  
Transport : \_\_\_\_\_  
L.R.No. : \_\_\_\_\_ Date : / /  
Vehicle No. : \_\_\_\_\_ No. of Case : 42.38

**Payment must be made within days.**

Sr.	Particulars	HSN Code	Quantity	Disc.	Rate	GST%	Amount
1	CFL 18 W PL Halonix Lead PL	85393110	10.00	15.25%	390.00	18.00	3305.25
<b>Sub Total</b>							<b>3,305.25</b>
<b>CLOSING BAL : 0.00</b>							
<b>USHA TOLL FREE NO 1800 1033 111</b>							
<b>GST Summary</b>							
	Taxable Amnt	SGST	CGST AMT	CGST	CGST AMT	Total GST	
GST @18.00	3347.63	9.00	301.29	9.00	301.29	602.58	
<b>Total :</b>	<b>3347.63</b>		<b>301.29</b>		<b>301.29</b>	<b>602.58</b>	
<b>Rs. Three thousand nine hundred fifty only.</b>							
<b>GST No: 24AARFJ0891K1ZW</b>							
<b>Bank Details: HDFC BANK LTD</b>							
A/C No: 50200058147440 IFSC CODE: HDFC0000101							
BRANCH: Dr YAGNIK ROAD BRANCH,RAJKOT							
<b>For, JIGNESH ELECTRIC STORE</b>							
For, Jignesh Electric Stores							
K.B. Pujaria							
Manager Partner							
Authorised Signatory							

PAID  
Ch. No. 252292596  
Bank ARI  
Date 24/11/21

Net Pay - 3900/-

Grand Total: 3,950.00

TERMS & CONDITIONS:  
1. GOODS ONCE SOLD WILL NOT BE TAKEN BACK.  
2. SUBJECT TO RAJKOT JURISDICTION. E. & O.E.

Note: 50% CN Attached this bill

**Registrar  
Atmiya University  
Rajkot**





**CHANDAN ELECTRIC SERVICE**

"Sneh Ashish", 20 New Jagnath, Rajkot - 360001 / M. 990 990 55 26 / 942 950 16 77  
Email: chandaneleservice@yahoo.com

Debit Memo		Tax Invoice				Original				
<b>To, Atmiya University</b> Rajkot 24-Gujarat Mobile No : 9874563210					Has Reverse Charges : No <b>Invoice No. : R-454</b> <b>Invoice Dt. : 16-08-2021</b> <b>Outstanding Balance: 3,201.00</b> Payment Should be make in 15 days.					
Sr	HSN	Particular	Qty	Rate	Disc %	Taxable Amount	CGST %	CGST Tax	SGST %	SGST Tax
1	94054090	AK 50W Led Flood Light	2 pc	1,350.00		2,700.00	6.0	162.00	6.0	162.00
2	85366910	Panama 6A 2 Pin Top <i>electric</i>	12 pc	12.50		150.00	9.0	13.50	9.0	13.50
<i>2) rate higher than mlt 0=25</i>										
<div style="border: 1px solid black; padding: 5px; display: inline-block;"> <b>PAID</b>                      Ch. No. <i>AT15P00228009860</i>                      Date <i>AT15</i>                      30/9/21                 </div>										
Bank : HDFC BANK    Branch : Dr. Yagnik Road RTGS/IFSC : HDFC0000101    A/C : 50200040487961						Amount    2,850.00 SGST        175.50 CGST        175.50				
Amount in Words: Three Thousand Two Hundred One Only GSTIN No : 24ABJPC0071B1ZJ						<b>Grand Total    3,201.00</b>				
<b>Terms &amp; Conditions:</b> 1. Interest 18% p.a. will be charged, if payment not made as per order's terms. 2. Goods once sold will not be taken back. 3. Guarantee & Warrantee are according to the manufacturer's terms and conditions. 4. All Trasactions are subject to Rajkot jurisdiction. 5. E & OE.						For, Chandan Electric Service <i>Sh</i> Proprietor, Authorised Signatory				

*[Signature]*

**Registrar**  
**Atmiya University**  
**Rajkot**





**ATMIYA UNIVERSITY**

NAAC – Cycle – 1  
AISHE: U-0967

Criterion- VII

IV&BP

KI 7.2

M 7.2.1

**CHANDAN ELECTRIC CORPORATION**

20, NEW JAGANATH, MARUTI COMPLEX, RAJKOT-360001.  
Phone: 0281-2467900 Email : chandan.elecorp@gmail.com

**DEBIT RETAIL INVOICE ORIGINAL**

**To, ATMIYA UNIVERSITY**  
FACULTY OF SCIENCE  
KALAWAD ROAD.  
**RAJKOT**  
Ph. No:  
Party's GST No:

**Invoice No: R 385** Date: 17/08/2021

Book No. : NO.AU FOS  
L.R. No.: : ELE.ACCE./PO/37  
Transport: : 2021-22  
Through: : DA.13-08-21

Sr	Particulars	HSN Code	Quantity	Rate	Dis.%	CGST%	Amount
	<b>ORDER NO.: 1798</b>						
✓	ANCH. ROMA PLATE 18- MODU. TERSA	8538	15.00	373.00	52.00	18.00	2,685.60
✓	ANCH. ROMA PLATE 12-MODU. TRESA	8538	50.00	318.00	52.00	18.00	7,632.00
✓	ANCH. ROMA PLATE 4 MODU. TRESA	8538	20.00	145.00	52.00	18.00	1,392.00
✓	ANCH. ROMA PLATE 3-MODU TRESA	8538	140.00	126.00	52.00	18.00	8,467.20
✓	ANCH. ROMA 10A 1-WAY SWITCH	8536	500.00	67.00	55.00	18.00	15,075.00
✓	ANCH. ROMA 10A SOCKET 2-IN-1	8536	250.00	145.00	52.00	18.00	17,400.00
✓	ANCH. ROMA 20-A 1-WAY SWITCH	8536	120.00	149.00	52.00	18.00	8,582.40
✓	ANCH. ROMA 20-A SOCKET HEAVY DUTY	8536	250.00	238.00	52.00	18.00	28,560.00
✓	ANCH. ROMA BLANK PLATE 1M	8538	50.00	31.00	52.00	18.00	744.00
✓	ANCH. ROMA BLANK PLATE 2M	8536	30.00	54.00	52.00	18.00	777.60
✓	ANCH. ROMA MO_MCB SP 10A	8536	10.00	250.00	50.00	18.00	1,250.00
✓	PANASONIC LED 20W PATTI - Tube Light Led	9405	100.00	180.00	10.71	12.00	16,072.20
	<b>ORDER NO.: 1805</b>						
✓	ANCH. ROMA PLATE 3-MODU TRESA	8538	60.00	126.00	52.00	18.00	3,628.80
✓	ANCH. ROMA 20-A 1-WAY SWITCH	8536	130.00	149.00	52.00	18.00	9,297.60
	①②③④⑤⑥⑦⑧ Plate & Socket						
	⑨⑩ Socket & Plate						
	⑪⑫ Socket & Plate						
	<b>PAID</b> Ch. No. 225950167 Bank ATIS Date 20/08/21						
	<b>Sub Total</b>		<b>1725.00</b>				<b>1,21,564.40</b>
<b>Bank Details: BANK OF BARODA</b> A/C No: 18800400005383 IFSC CODE: BARB0DBRACE BRANCH: RACE-COURSE BRANCH, RAJKOT.							<b>Sub Total</b> SGST 10,458.63 CGST 10,458.63
<b>GST Summary</b>	<b>Taxable Amnt</b>	<b>SGST</b>	<b>SGST AMT</b>	<b>CGST</b>	<b>CGST AMT</b>	<b>Total GST</b>	
GST @18.00	105492.20	9.00	9494.29	9.00	9494.29	18988.59	
GST @12.00	16072.20	6.00	964.33	6.00	964.33	1928.66	
<b>Total :</b>	<b>121564.40</b>		<b>10458.63</b>		<b>10458.63</b>	<b>20917.26</b>	
<b>Rs. One lakh forty two thousand four hundred eighty two only.</b>							<b>Round Off</b> 0.34
<b>GST No:24ABFPC2693F2ZY</b>							<b>Grand Total</b> <b>1,42,482.00</b>
<b>TERMS:</b> Subject to RAJKOT Jurisdiction. Payment 100% within 15 Days only. E. & O. E.							<b>For, CHANDAN ELECTRIC CORPORATION</b> 

**Registrar  
Atmiya University  
Rajkot**







**ATMIYA  
UNIVERSITY**

**NAAC – Cycle – 1  
AISHE: U-0967**

**Criterion- VII**

**IV&BP**

**KI 7.2**

**M 7.2.1**

**REVA ELECTRICALS**

SANGANWA CHOWK RAJDEV STREET RAJKOT  
Phone: 2234278 2228916 99041 00075 Email: 93693 93694

**DEBIT TAX INVOICE ORIGINAL**

To, **ATMIYA UNIVERSITY**  
YOGIDHAM GURUKUL  
KALAWAD ROAD  
RAJKOT (Gujarat)  
Ph. No:  
Party's GST No:

Invoice No: **TG 602** Date: **17/06/2021**  
Challan No. : 17786 Date : 15/06/21  
Transport :  
L.R.No. : Date : / /  
Vehicle No. : No. of Case :

**Payment must be made within days.**

Sr.	Particulars	HSN Code	Quantity	Disc.	Rate	GST%	Amount
1	LED LAMP 18W <i>Wipro</i> <i>Leol PL</i>	8539	10.00	10.714	380.00	12.00	3392.87
					<b>10.00</b>	<b>Sub Total</b>	<b>3,392.87</b>

**PAID**

*ARTIJA* Ch. No. **208722370**

Bank *ARTIJA*

Date **12-7-21**

HAVELLS TOLL FREE NO 1800 103 1313 USHA TOLL FREE NO 1800 1033 111 CROMPTON TOLL FREE NO 1800 419 0505						<b>Sub Total</b> 3,392.87 SGST 203.57 CGST 203.57
<b>GST Summary</b>	<b>Taxable Amnt</b>	<b>SGST</b>	<b>SGST AMT</b>	<b>CGST</b>	<b>CGST AMT</b>	<b>Total GST</b>
GST @12.00	3392.87	6.00	203.57	6.00	203.57	407.14
<b>Total :</b>	3392.87		203.57		203.57	407.14

**Round Off** -0.01  
**Grand Total** **3,800.00**

**Rs. Three thousand eight hundred only.**

GST No: 24ACYP0074B1ZM  
Bank Details: **HDFC BANK LTD,**  
A/C No: 50200013922771 IFSC CODE: HDFC0000101  
BRANCH: Dr YAGNIK ROAD BRANCH, RAJKOT

**Reva Electricals**  
Proprietor  
Authorised Signatory

*[Handwritten Signature]*

**Registrar  
Atmiya University  
Rajkot**





**CHANDAN ELECTRIC SERVICE**  
"Sneh Ashish", 20 New Jagnath, Rajkot - 360001. M: 990 990 55 26 / 942 950 16 77  
Email: chandaneleservice@yahoo.com

Debit Memo		Tax Invoice				Original				
To, Atmiya University-Faculty of Science Rajkot 24-Gujarat					Has Reverse Charges : No Invoice No. : R-277 Invoice Dt. : 19-07-2021 Outstanding Balance: 1,812.00 Payment Should be make in 15 days.					
Sr	HSN	Particular	Qty	Rate	Disc %	Taxable Amount	CGST %	CGST Tax	SGST %	SGST Tax
1	84145190	Order No: SC07-106 Date: 12-07-2021 Havells 300MM DSP Ventilating Fan <i>Invoice for</i>	1 pc	2,310.00	40	1,386.00	9.0	124.74	9.0	124.74
<div style="border: 1px solid black; padding: 5px; display: inline-block;"> <b>PAID</b>            Ch. No. <i>Atmiya</i> 16315323            Bank <i>Atmiya</i>            Date <i>12/07/21</i> </div>										
Bank : HDFC BANK Branch : Dr. Yagnik Road							Amount 1,386.00			
RTGS/IFSC : HDFC0000101 A/C : 50200040487961							SGST 124.74			
Amount in Words: One Thousand Six Hundred Thirty Five Only							CGST 124.74			
GSTIN No : 24ABJPC0071B1ZJ							Rounding -0.48			
							<b>Grand Total 1,635.00</b>			
<b>Terms &amp; Conditions:</b> 1. Interest 18% p.a. will be charged, if payment not made as per order's terms. 2. Goods once sold will not be taken back. 3. Guarantee & Warrantee are according to the manufacturer's terms and conditions. 4. All Transactions are subject to Rajkot jurisdiction. 5. E & OE.							<b>For, Chandan Electric Service</b> <i>For Chandan Electric Service</i> Proprietor: Authorised Signatory			

Page 1 of 1

**Registrar**  
**Atmiya University**  
**Rajkot**





**ATMIYA  
UNIVERSITY**

**NAAC – Cycle – 1  
AISHE: U-0967**

**Criterion- VII**

**IV&BP**

**KI 7.2**

**M 7.2.1**

**AKSHAR ELECTRONICS**

PLOT NO. 72&73, AKSHAR, 5 NEW VISHV NAGAR, NR. PATEL BOARDING,  
MAVDI PLOT, RAJKOT - 360 004, GUJARAT  
MO. 89089 27027, 97127 27400

DEBIT		TAX INVOICE				ORIGINAL	
<b>TO, ATMIYA UNIVERSITY FACULTY OF SCIENCE</b> YOGIDHAM GURUKUL, KALAWAD ROAD, RAJKOT GUJARAT State Code: 24 <b>GST No: UNREGISTERED PERSON</b>		<b>Invoice No. AE7</b> Date: 03/03/2022 Challan No. : Date: Transport : Date: L. R. No. :					
No.	Description of Goods	HSN	Gst%	Quantity	Rate	Amount	
1	100W FLOOD LIGHT <i>Flood Light</i>	9405	12.00	2	1,607.14	3,214.28	
<b>AKSHAR ELECTRONICS</b>							
<b>GST No: 24AHYPD2231P1Z0 (ending with ZERO)</b>						Sub Total 3,214.28	
<b>Tax Summary</b>							
HSN Code	Taxable Amt	SGST	SGST AMT	CGST	CGST AMT	Total GST	
9405	3,214.28	6.00	192.86	6.00	192.86	385.72	
						SGST 192.86 CGST 192.86 Round Off 0.00	
<b>Total</b>		<b>3,214.28</b>	<b>192.86</b>	<b>192.86</b>	<b>385.72</b>	<b>Grand Total 3,600.00</b>	
<b>Total (In Words): Three Thousand Six Hundred Only</b>						<b>For, AKSHAR ELECTRONICS</b>	
<b>Bank Details:</b>							
Bank Name : HDFC Bank CL Ring Road A/C No. : 59 200 300 200 300 IFSC Code : HDFC009028						 Authorized Signatory	
Subject to RAJKOT jurisdiction. E. & O. E.						Certified that the particulars given above are true and correct.	

*[Handwritten Signature]*

**Registrar  
Atmiya University  
Rajkot**







**ATMIYA  
UNIVERSITY**

**NAAC – Cycle – 1  
AISHE: U-0967**

**Criterion- VII**

**IV&BP**

**KI 7.2**

**M 7.2.1**

**PUJARA LIGHTING**

SANGANWA CHOWK Opp ABC MEDICAL RAJKOT  
Phone: 0281-2243149 93693 93694 Email: jignesh\_ele\_stores@yahoo.co.in

**DEBIT INVOICE ORIGINAL**

**To, ATMIYA UNIVERSITY FACULTY OF SCIENCE**  
KALAWAD ROAD,  
**RAJKOT (Gujarat)**  
Ph. No:

Party's GST No:

Invoice No: 245 Date: 30/12/2020  
Challan No. : 2439 Date : / /  
Transport :  
L.R.No. : Date : / /  
Vehicle No. : No. of Case :

**Payment must be made within days.**

Sl. No.	Description	HSN	Qty	Rate	Amount	Tax	Total
1	SURYA LED T-5 20W	940511090	30.00	10.715	190.00	12.00	5089.25
			<b>30.00</b>	<b>Sub Total</b>			<b>5,089.25</b>

**PAYD**

000610  
HDFC  
30/12/2020

<b>HAVELLS TOLL FREE NO 1800 103 1313</b>						<b>Sub Total</b>		<b>5,089.25</b>
<b>USHA TOLL FREE NO 1800 1033 111</b>						<b>SGST</b>		<b>305.36</b>
<b>CROMPTON TOLL FREE NO 1800 419 0505</b>						<b>CGST</b>		<b>305.36</b>
<b>GST Summary</b>	<b>Taxable Amt</b>	<b>SGST</b>	<b>SGST AMT</b>	<b>CGST</b>	<b>CGST AMT</b>	<b>Total GST</b>		
GST @12.00	5089.25	6.00	305.36	6.00	305.36	610.72		
<b>Total :</b>	<b>5089.25</b>		<b>305.36</b>		<b>305.36</b>	<b>610.72</b>		
						<b>Round Off</b>	<b>0.03</b>	
						<b>Grand Total</b>	<b>5,700.00</b>	

**Rs. Five thousand seven hundred only.**

**GST No: 24AXZPP1937H1ZW**

Bank Details: **HDFC BANK LTD,**  
A/C No: 50200023121211 IFSC CODE: HDFC0000101  
BRANCH: Dr YAGNIK ROAD, RAJKOT

**For, PUJARA LIGHTING**  
**PUJARA LIGHTING**  
*Kawal*  
MANAGER/PROPRIETOR  
Authorised Signatory

**TERMS & CONDITIONS:**  
1. GOODS ONCE SOLD WILL NOT BE TAKEN BACK.  
2. SUBJECT TO RAJKOT JURISDICTION. E. & O.E.

*[Handwritten Signature]*

**Registrar  
Atmiya University  
Rajkot**





**ATMIYA UNIVERSITY**

NAAC – Cycle – 1  
AISHE: U-0967

Criterion- VII

IV&BP

KI 7.2

M 7.2.1

**PUJARA LIGHTING**

SANGANWA CHOWK Opp ABC MEDICAL RAJKOT  
Phone: 0281-2243149 93693 93694 Email: iicnesh\_ele\_stores@yahoo.co.in

**DEBIT INVOICE ORIGINAL**

**To, ATMIYA UNIVERSITY FACULTY OF ENGINEERING AND TECHNOLOGY**

**RAJKOT (Gujarat)**  
Ph. No: \_\_\_\_\_

Party's GST No: \_\_\_\_\_

Challan No. : 2437 Date : / /  
Transport : \_\_\_\_\_  
L.R.No. : \_\_\_\_\_ Date : / /  
Vehicle No. : \_\_\_\_\_ No.of Case : \_\_\_\_\_

**Payment must be made within days.**

Sl.	Description	HSN	Qty	Unit	Rate	Amount	Tax	Total
1	SURYA LED T-5 20W	940511090	30.00		10.715	190.00	12.00	5089.25
					<b>30.00</b>	<b>Sub Total</b>		<b>5,089.25</b>

<b>HAVELLS TOLL FREE NO 1800 103 1313</b>							<b>Sub Total</b> 5,089.25 <b>SGST</b> 305.36 <b>CGST</b> 305.36
<b>USHA TOLL FREE NO 1800 1033 111</b>							
<b>CROMPTON TOLL FREE NO 1800 419 0505</b>							
<b>GST Summary</b>	<b>Taxable Amt</b>	<b>SGST</b>	<b>SGST AMT</b>	<b>CGST</b>	<b>CGST AMT</b>	<b>Total GST</b>	
GST @12.00	5089.25	6.00	305.36	6.00	305.36	610.72	
<b>Total :</b>	<b>5089.25</b>		<b>305.36</b>		<b>305.36</b>	<b>610.72</b>	<b>Grand Total</b> 5,700.00

**Rs. Five thousand seven hundred only.**

**GST No: 24AXZPP1937H1ZW**

Bank Details: **HDFC BANK LTD,**  
A/C No: 50200023121211 IFSC CODE: HDFC000101  
BRANCH: Dr YAGNIK ROAD, RAJKOT

**TERMS & CONDITIONS:**  
1. GOODS ONCE SOLD WILL NOT BE TAKEN BACK.  
2. SUBJECT TO RAJKOT JURISDICTION. E.& O.E.

**For, PUJARA LIGHTING**  
**PUJARA LIGHTING**  
*[Signature]*  
MANAGER/PROPRIETOR  
Authorised Signatory

**PAID**  
Ch. No. 000604  
HDFC  
Date 30-12-2020

*[Signature]*

**Registrar  
Atmiya University  
Rajkot**





**ATMIYA  
UNIVERSITY**

**NAAC – Cycle – 1  
AISHE: U-0967**

**Criterion- VII**

**IV&BP**

**KI 7.2**

**M 7.2.1**

**PUJARA LIGHTING**

SANGANWA CHOWK Opp ABC MEDICAL RAJKOT  
Phone: 0281-2243149 93693 93694 Email: ijnesh\_ele\_stores@yahoo.co.in

**DEBIT INVOICE ORIGINAL**

**To, ATMIYA UNIVERSITY**  
YOGI DHAM,  
KALAWAD ROAD,  
**RAJKOT (Gujarat)**  
Ph. No:

Party's GST No:

Invoice No: GT 256 Date: 09/12/2020  
Challan No. : 2434 Date : / /  
Transport :  
L.R.No. : Date : / /  
Vehicle No. : No. of Case :

**Payment must be made within days.**

Sr	Particulars	HSN/SAC	Quantity	Disc	Rate	GST%	Amount	
1	GREAT WHITE LED RDL 15W <i>Panel Light led</i>	940511090	4.00		10,715	400.00	12.00	1428.56
<b>Sub Total</b>								<b>1,428.56</b>

**PAID**

Ch. No. *00vh90*

Bank *HDFC*

Date *22 Dec 2020*

<b>HAVELLS TOLL FREE NO 1800 103 1313</b> <b>USHA TOLL FREE NO 1800 1033 111</b> <b>CROMPTON TOLL FREE NO 1800 419 0505</b>						<b>Sub Total</b> 1,428.56 SGST 85.71 CGST 85.71
<b>GST Summary</b>	<b>Taxable Amnt</b>	<b>SGST</b>	<b>SGST AMT</b>	<b>CGST</b>	<b>CGST AMT</b>	<b>Total GST</b>
GST @12.00	1428.56	6.00	85.71	6.00	85.71	171.42
<b>Total :</b>	1428.56		85.71		85.71	171.42

**Grand Total** 1,600.00

**Rs. One thousand six hundred only.**

GST No: 24AXZPP1937H1ZW  
Bank Details: **HDFC BANK LTD,**  
A/C No: 50200023121211 IFSC CODE: HDFC0000101  
BRANCH: Dr YAGNIK ROAD, RAJKOT

**For, PUJARA LIGHTING**  
PUJARA LIGHTING.  
*[Signature]*  
PROPRIETOR,  
Authorised Signatory

**TERMS & CONDITIONS:**  
1. GOODS ONCE SOLD WILL NOT BE TAKEN BACK.  
2. SUBJECT TO RAJKOT JURISDICTION. E.& O.E.

*[Signature]*

**Registrar  
Atmiya University  
Rajkot**







**ATMIYA UNIVERSITY**

**NAAC – Cycle – 1  
AISHE: U-0967**

**Criterion- VII**

**IV&BP**

**KI 7.2**

**M 7.2.1**

PUJARA LIGHTING							
SANGANWA CHOWK Opp ABC MEDICAL RAJKOT Phone: 0281-2243149 93693 93694 Email: ilanesh_ele_stores@yahoo.co.in							
DEBIT				INVOICE		ORIGINAL	
To, ATMIYA UNIVERSITY FACULTY OF SCIENCE KALAWAD ROAD, RAJKOT (Gujarat) Ph. No:				Invoice No: GT 236 Date: 03/12/2020		Challan No. : R-2095 Date : / / Transport : L.R.No. : Date : / / Vehicle No. : No.of Case :	
Party's GST No:				Payment must be made within days.			
Sl	Particulars	HSN Code	Quantity	Disc.	Rate	GST%	Amount
1	GREAT WHITE LED RDL 15W	940511090	8.00	10.715	400.00	12.00	2857.12
2	GREAT WHITE LED RDL 12W 6K	940511090	8.00	10.715	350.00	12.00	2499.98
				16.00	Sub Total		5,357.10
HAVELLS TOLL FREE NO 1800 103 1313 USHA TOLL FREE NO 1800 1033 1111 CROMPTON TOLL FREE NO 1800 419 0505				PO NO. AU Fos/led/PO/38-2020-21 dt-30/11/2020		Sub Total 5,357.10 SGST 321.43 CGST 321.43	
GST Summary		Taxable Amnt	SGST	SGST AMT	CGST	CGST AMT	Total GST
GST @12.00		5357.10	6.00	321.42	6.00	321.42	642.85
Total :		5357.10		321.42		321.42	642.85
							Round Off 0.04
							<b>Grand Total 6,000.00</b>
Rs. Six thousand only.							
GST No: 24AXZPP1937H1ZW							
Bank Details: HDFC BANK LTD, A/C No: 50200023121211 IFSC CODE: HDFC0000101 BRANCH: Dr YAGNIK ROAD, RAJKOT							
TERMS & CONDITIONS: 1. GOODS ONCE SOLD WILL NOT BE TAKEN BACK. 2. SUBJECT TO RAJKOT JURISDICTION. E.& O.E.				For, PUJARA LIGHTING PUJARA LIGHTING <i>[Signature]</i> PROPRIETOR Authorised Signatory			

*[Signature]*

**Registrar  
Atmiya University  
Rajkot**





**ATMIYA  
UNIVERSITY**

**NAAC – Cycle – 1  
AISHE: U-0967**

**Criterion- VII**

**IV&BP**

**KI 7.2**

**M 7.2.1**

**PUJARA LIGHTING**

SANGANWA CHOWK Opp ABC MEDICAL RAJKOT  
Phone: 0281-2243149 93694 Email: ilanesh\_ele\_stores@yahoo.co.in

**DEBIT INVOICE ORIGINAL**

**To, ATMIYA UNIVERSITY FACULTY OF SCIENCE**  
KALAWAD ROAD,  
RAJKOT (Gujarat)  
Ph. No:

Invoice No: GT 233 Date: 02/12/2020  
Challan No. : 2409 Date : / /  
Transport : Date : / /  
L.R.No. : Date : / /  
Vehicle No. : No.of Case :

Party's GST No: **Payment must be made within days.**

Sr	Particulars	HSN Code	Quantity	Disc.	Rate	GST%	Amount	
1	GREAT WHITE LED RDL 12W 6K	940511090	4.00	10.715	350.00	12.00	1249.99	
2	GREAT WHITE LED RDL 15W	940511090	24.00	10.715	400.00	12.00	8571.36	
							<b>28.00</b>	
							<b>Sub Total</b>	<b>9,821.35</b>

**PAID**

Ch. No. 007499  
Bank HDFC  
22-Dec-2020

HAVELLS TOLL FREE NO 1800 103 1313	PO NO. AUFos/led/PO/38-2020-21 dt-30/11/2020	<b>Sub Total</b>	<b>9,821.35</b>
USHA TOLL FREE NO 1800 1033 111		SGST	589.28
CROMPTON TOLL FREE NO 1800 419 0505		CGST	589.28

GST Summary	Taxable Amnt	SGST	SGST AMT	CGST	CGST AMT	Total GST
GST @12.00	9821.35	6.00	589.28	6.00	589.28	1178.56
<b>Total :</b>	<b>9821.35</b>		<b>589.28</b>		<b>589.28</b>	<b>1178.56</b>

Round Off 0.09

**Grand Total 11,000.00**

**Rs. Eleven thousand only.**

GST No: 24AXZPP1937H1ZW

Bank Details: **HDFC BANK LTD,**  
A/C No: 50200023121211 IFSC CODE: HDFC0000101  
BRANCH: Df YAGNIK ROAD, RAJKOT

**For, PUJARA LIGHTING**  
PUJARA LIGHTING.  
Authorised Signatory

**TERMS & CONDITIONS:**  
1. GOODS ONCE SOLD WILL NOT BE TAKEN BACK.  
2. SUBJECT TO RAJKOT JURISDICTION. - E & O.E.

**Registrar  
Atmiya University  
Rajkot**





**ATMIYA UNIVERSITY**

NAAC – Cycle – 1  
AISHE: U-0967

Criterion- VII

IV&BP

KI 7.2

M 7.2.1

**JIGNESH ELECTRIC STORES**

SANGANWA CHOKE RAJDEV STREET RAJKOT-360001  
Phone: 0281-2234278 Email: jignesh\_ele\_stores@yahoo.co.in

DEBIT **INVOICE** ORIGINAL

To, **ATMIYA UNIVERSITY**  
ATMIYA COLLAGE KALAWAD ROAD

RAJKOT (Gujarat)  
Ph. No:

Party's GST No:

Invoice No: **GT 1040** Date: 12/11/2020

Challan No. : 40016 Date : / /  
Transport DINESH GUPTA  
L.R.No. : Date : / /  
Vehicle No. : No.of Case : 0,00

Payment must be made within days.

Sl.	Particulars	HSN-Code	Quantity	Disc.	Rate	GST%	Amount
1	GREAT WHITE LED LAMP 12W	9405	30.00	10.715	130.00	12.00	3482.12
			<b>30.00</b>		<b>Sub Total</b>		<b>3,482.12</b>

Stamp area with fields for Ch. No., Bank, and Date.

HAVELLS TOLL FREE NO 1800 103 1313  
USHA TOLL FREE NO 1800 1033 111  
CROMPTON TOLL FREE NO 1800 419 0505

Sub Total **3,482.12**  
SGST 208.93  
CGST 208.93

GST Summary	Taxable Amnt	SGST	SGST AMT	CGST	CGST AMT	Total GST
GST @12.00	3482.12	6.00	208.93	6.00	208.93	417.86
<b>Total :</b>	<b>3482.12</b>		<b>208.93</b>		<b>208.93</b>	<b>417.86</b>

Round Off 0.02  
**Grand Total 3,900.00**

Rs. Three thousand nine hundred only.

GST No:24ACYPP0076D1ZG

Bank Details: **HDFC BANK LTD**  
A/C No: 50200029061238 IFSC CODE: HDFC0000101  
BRANCH: Dr YAGNIK ROAD BRANCH,RAJKOT

For, JIGNESH ELECTRIC STORES

For, Jignesh Electric Stores

Signature of Authorised Signatory

Authorised Signatory

Handwritten signature of Registrar

**Registrar  
Atmiya University  
Rajkot**







**ATMIYA UNIVERSITY**

NAAC – Cycle – 1  
AISHE: U-0967

Criterion- VII

IV&BP

KI 7.2

M 7.2.1

**JIGNESH ELECTRIC STORES**

SANGANWA CHOKE RAJDEV STREET RAJKOT-360001  
Phone: 0281-2234278 Email: jignesh\_ele\_stores@yahoo.co.in

ORIGINAL

**DEBIT INVOICE**

**To, ATMIYA UNIVERSITY**  
ATMIYA COLLAGE KALAWAD ROAD  
**RAJKOT (Gujarat)**  
Ph. No:  
Party's GST No:

Invoice No: GT 1030 Date: 11/11/2020  
Challan No. : 40003 Date : / /  
Transport :  
L.R.No. : Date : / /  
Vehicle No. : No.of Case : 0.00

**Payment must be made within days.**

Sr	Particulars	Tax Code	Quantity	Disc.	Rate	GST%	Amount
1	GREAT WHITE LED LAMP 5W	9405	12.00	10.715	55.00	12.00	589.28
2	GREAT WHITE LED LAMP 9W	9405	12.00	10.715	60.00	12.00	642.85
3	GREAT WHITE LED LAMP 12W	9405	3.00	10.715	130.00	12.00	348.21
<b>Sub Total</b>							<b>1,580.34</b>

PAID

Ch. No: 00052  
Bank: HDFC  
Date: 9-12-2020

HAVELLS TOLL FREE NO 1800 103 1313 USHA TOLL FREE NO 1800 1033 111 CROMPTON TOLL FREE NO 1800 419 0505						<b>Sub Total</b> 1,580.34 SGST 94.82 CGST 94.82
<b>GST Summary</b>	<b>Taxable Amt</b>	<b>SGST</b>	<b>CGST</b>	<b>CGST AMT</b>	<b>Total GST</b>	
GST @12.00	1580.34	6.00	94.82	94.82	189.64	
<b>Total :</b>	<b>1580.34</b>		<b>94.82</b>	<b>94.82</b>	<b>189.64</b>	

**Grand Total 1,770.00**

**Rs. One thousand seven hundred seventy only.**

GST No: 24ACYPP0076D12G  
Bank Details: **HDFC BANK LTD**  
A/C No: 50200029061238 IFSC CODE: HDFC0000101  
BRANCH: Dr YAGNIK ROAD BRANCH,RAJKOT

**For, JIGNESH ELECTRIC STORES**  
For, Jignesh Electric Stores.  
Proprietor.  
Authorised Signatory

**TERMS & CONDITIONS:**  
1. GOODS ONCE SOLD WILL NOT BE TAKEN BACK.  
2. SUBJECT TO RAJKOT JURISDICTION. E & O. E.

*[Handwritten Signature]*

**Registrar  
Atmiya University  
Rajkot**





**ATMIYA  
UNIVERSITY**

**NAAC – Cycle – 1  
AISHE: U-0967**

**Criterion- VII**

**IV&BP**

**KI 7.2**

**M 7.2.1**

For All Your Electrical Needs. **CHANDAN Electric Service** Since 1988

"Sneh Ashish", 20 New Jagmath  
Rajkot - 360001 P:0281-2467801  
E:chandaneleservice@yahoo.com  
M:+91 990 990 5526, +91 942 950 1677

**Debit Memo Tax Invoice Original**

To, Atmiya University  
Rajkot  
24-Gujarat  
Mobile No : 9874563210

Has Reverse Charges : No  
Invoice No. : R-502 Invoice Dt. : 10-11-2020  
Outstanding Balance: 48,384.00  
Payment Should be make in 15 days.

Sr	HSN	Particular	Qty	Rate	Disc %	Taxable Amount	CGST %	SGST %	Tax
1	9405	Order No: SC11-76 Date: 06/11/2020 BN 12W Round Cylinder Led Cob Light	72 pc	600.00		43,200.00	6.0	6.0	2,592.00

**PAID**

Ch. No. 000665

Bank. HDFC

Date. 12-12-2020

Bank : HDFC BANK Branch : Dr. Yagnik Road  
RTGS/IFSC : HDFC0000101 A/C : 50200040487961

Amount in Words: Forty Eight Thousand Three Hundred Eighty Four Only  
GSTIN No : 24ABJPC0071B1ZJ  
P.O.No.AU/led/PO/31A-2020-21 Dt:06-11-2020

Amount 43,200.0  
SGST 2,592.0  
CGST 2,592.0

**Grand Total 48,384.0**

**For, Chandan Electric Service**

Terms & Conditions:  
1. Interest 18% p.a. will be charged, if payment not made as per order's terms.  
2. Goods once sold will not be taken back.  
3. Guarantee & Warrantee are according to the manufacturer's terms and conditions.  
4. All Trasactions are subject to Rajkot jurisdiction.  
5. E & OE.

For: Chandan Electric Service  
Authorised Signator

Page 1 of 1

We deal in the most trusted names in the electrical field.

HAVELLS Crabtree GreatWhite LARSEN & TOUBRO norisys GEM ADLER DIGITECH RR V-GUARD

**Registrar  
Atmiya University  
Rajkot**





**ATMIYA  
UNIVERSITY**

**NAAC – Cycle – 1  
AISHE: U-0967**

**Criterion- VII**

**IV&BP**

**KI 7.2**

**M 7.2.1**

**PUJARA LIGHTING**

SANGANWA CHOWK Opp ABC MEDICAL RAJKOT  
Phone: 0281-2243149 93693 93694 Email: Itanesh\_ele\_stores@yahoo.co.in

**DEBIT INVOICE ORIGINAL**

**To, ATMIYA UNIVERSITY FACULTY OF SCIENCE**  
KALAWAD ROAD,  
RAJKOT (Gujarat)  
Ph. No:  
Party's GST No:

Invoice No: 25 Date: 09/12/2020  
Challan No. : R-2117 Date : / /  
Transport :  
L.R.No. : Date : / /  
Vehicle No. : No.of Case :

**Payment must be made within days.**

Sl. No.	Description	HSN Code	Qty	Unit Price	Net Amount	Tax	Total
1	GREAT WHITE LED RDL 20W	940511090	8.00	10.715	550.00	12.00	3928.54
<b>Sub Total</b>							<b>3,928.54</b>

**PAID**

000009

Ch. No. HDPC

22-DEC-2020

HAVELLS TOLL FREE NO 1800 103 1313  
USHA TOLL FREE NO 1800 1033 111  
CROMPTON TOLL FREE NO 1800 419 0505

PO NO. AUFos/led/PO/38-2020-21 dt-30/11/2020

<b>Sub Total</b>	<b>3,928.54</b>
SGST	235.71
CGST	235.71
Round Off	0.04
<b>Grand Total</b>	<b>4,400.00</b>

GST Summary	Taxable Amnt	SGST	SGST AMT	CGST	CGST AMT	Total GST
GST @12.00	3928.54	6.00	235.71	6.00	235.71	471.42
<b>Total :</b>	<b>3928.54</b>		<b>235.71</b>		<b>235.71</b>	<b>471.42</b>

**Rs. Four thousand four hundred only.**

GST No: 24AXZPP1937H1ZW

Bank Details: **HDFC BANK LTD,**  
A/C No: 50200023121211, IFSC CODE: HDFC0000101  
BRANCH: Dr YAGNIK ROAD, RAJKOT

**For, PUJARA LIGHTING**  
**PUJARA LIGHTING**  
Proprietor  
Authorized Signatory

**TERMS & CONDITIONS:**  
1. GOODS ONCE SOLD WILL NOT BE TAKEN BACK.  
2. SUBJECT TO RAJKOT JURISDICTION. E.& O.E.

**Registrar  
Atmiya University  
Rajkot**







**ATMIYA  
UNIVERSITY**

**NAAC – Cycle – 1  
AISHE: U-0967**

**Criterion- VII**

**IV&BP**

**KI 7.2**

**M 7.2.1**

**CHANDAN Electric Service**  
Since 1986

"Sneh Ashish", 20 New Jagnath  
Rajkot - 360001 P:0281-2467801  
E:chandaneleservice@yahoo.com  
M:+919909905526, +919429501677

**Debit Memo Tax Invoice Original**

To, Atmiya University  
FOET, Rajkot  
24-Gujarat  
Mobile No : 9874563210

Has Reverse Charges : No  
Invoice No. : R-383 Invoice Dt. : 30-09-2020  
**Outstanding Balance: 6,800.00**  
Payment Should be make in 15 days.

Sr	HSN	Particular	Qty	Rate	Disc %	Taxable Amount	CGST %	CGST Tax	SGST %	SGST Tax
1	8539	Order No: SC09-322 Date: 30/09/2020 Wipro 18-W Led PL	20 pc	303.57		6,071.40	6.0	364.28	6.0	364.28

**PAID**

Ch. No. 000228  
Bank HDFC  
Date 7-10-2020

Bank : HDFC BANK Branch : Dr. Yagnik Road  
RTGS/IFSC : HDFC0000101 A/C : 50200040487961  
Amount in Words: Six Thousand Eight Hundred Only  
GSTIN No : 24ABJPC0071B1ZJ

Amount 6,071.40  
SGST 364.28  
CGST 364.28  
Rounding 0.04  
**Grand Total 6,800.00**

**Terms & Conditions:**  
1. Interest 18% p.a. will be charged, if payment not made as per order's terms  
2. Goods once sold will not be taken back.  
3. Guarantee & Warrantee are according to the manufacturer's terms and conditions.  
4. All Trasactions are subject to Rajkot jurisdiction.  
5. E & OE.

**For, Chandan Electric Service**  
*[Signature]*  
Authorised Signatory

Page 1 of 1

We deal in the most trusted names in the electrical field.

HAVELLS Grabtree GreatWhite LARSEN & TOUBRO norisys SM ADLER DIGITECH RR V-GUARD

*[Signature]*

**Registrar  
Atmiya University  
Rajkot**





**ATMIYA  
UNIVERSITY**

**NAAC – Cycle – 1  
AISHE: U-0967**

**Criterion- VII**

**IV&BP**

**KI 7.2**

**M 7.2.1**

**PUJARA LIGHTING**

SANGANWA CHOWK Opp ABC MEDICAL RAJKOT  
Phone: 0281-2243149 93693 93694 Email: jianesh\_ele\_stores@yahoo.co.in

**DEBIT INVOICE ORIGINAL**

**To, ATMIYA UNIVERSITY FACULTY OF**  
BUSINESS AND COMMERCE  
YOGI DHAM,  
KALAWAD ROAD,  
RAJKOT (Gujarat)  
Ph. No:  
Party's GST No:

Challan No. : 2438/R1521 Date : / /  
Transport R/2386  
L.R.No. : Date : / /  
Vehicle No. : No.of Case :

**Payment must be made within days.**

Sr.	Description	HSN	Rate	Qty	Amount	Tax	Amount
1	SURYA LED T-5 20W	940511090	30.00	10.715	190.00	12.00	5089.25
			<b>30.00</b>	<b>Sub Total</b>			<b>5,089.25</b>

**PAID**

000605

HDFC

30-12-2020

<b>HAVELLS TOLL FREE NO 1800 103 1313</b> <b>USHA TOLL FREE NO 1800 1033 111</b> <b>CROMPTON TOLL FREE NO 1800 419 0505</b>						<b>Sub Total</b> 5,089.25 <b>SGST</b> 305.36 <b>CGST</b> 305.36
<b>GST Summary</b>	<b>Taxable Amnt</b>	<b>SGST</b>	<b>SGST AMT</b>	<b>CGST</b>	<b>CGST AMT</b>	<b>Total GST</b>
GST @12.00	5089.25	6.00	305.36	6.00	305.36	610.72
<b>Total :</b>	<b>5089.25</b>		<b>305.36</b>		<b>305.36</b>	<b>610.72</b>

**Rs. Five thousand seven hundred only.**

**GST No: 24AXZPP1937H1ZW**

Bank Details: **HDFC BANK LTD,**  
A/C No: 50200023121211 IFSC CODE: HDFC0000101  
BRANCH: Dr YAGNIK ROAD, RAJKOT

**For, PUJARA LIGHTING**  
**For, PUJARA LIGHTING**  
*[Signature]*  
Manager/Proprietor  
Authorised Signatory

**TERMS & CONDITIONS:**  
1. GOODS ONCE SOLD WILL NOT BE TAKEN BACK.  
2. SUBJECT TO RAJKOT JURISDICTION. E.& O.E.

*[Signature]*

**Registrar  
Atmiya University  
Rajkot**





**ATMIYA UNIVERSITY**

NAAC – Cycle – 1  
AISHE: U-0967

Criterion- VII

IV&BP

KI 7.2

M 7.2.1

**JIGNESH ELECTRIC STORES**

SANGANWA CHOKE RAJDEV STREET RAJKOT-360001  
Phone: 0281-2234278 Email: jignesh\_ele\_stores@yahoo.co.in

**DEBIT INVOICE ORIGINAL**

To, **ATMIYA UNIVERSITY FACULTY OF**  
ENGINEERING & TECHNOLOGY  
KALAWAD ROAD  
**RAJKOT (Gujarat)**  
Ph. No:

Party's GST No:

Invoice No: 01248 Date: 27/06/2020  
Challan No. : 39334 Date :26/06/20  
Transport : TEJASBHAI  
L.R.No. : Date : / /  
Vehicle No. : No.of Case : 0.00

**Payment must be made within days.**

Sl	DESCRIPTION	UQC	QTY	UNIT PRICE	TAXABLE AMT	CGST	SGST	AMOUNT
1	GREAT WHITE LED LAMP 9W	9405	10.00	10.715	60.00	12.00		535.71
2	GREAT WHITE LED LAMP 5W	9405	10.00	10.715	55.00	12.00		491.07
				<b>20.00</b>	<b>Sub Total</b>			<b>1,026.78</b>

**PAID**  
499  
HDFC  
28/06/20

HAVELLS TOLL FREE NO 1800 103 1313  
USHA TOLL FREE NO 1800 1033 111  
CROMPTON TOLL FREE NO 1800 419 0505

**Sub Total 1,026.78**  
SGST 61.61  
CGST 61.61

GST Summary	Taxable Amt	SGST	SGST AMT	CGST	CGST AMT	Total GST
GST @12.00	1026.78	6.00	61.61	6.00	61.61	123.22
<b>Total :</b>	<b>1026.78</b>		<b>61.61</b>		<b>61.61</b>	<b>123.22</b>

**Grand Total 1,150.00**

**Rs. One thousand one hundred fifty only.**

GST No:24ACYPP0076D1ZG

Bank Details: **HDFC BANK LTD**  
A/C No: 50200029061238 IFSC CODE: HDFC0000101  
BRANCH: Dr YAGNIK ROAD BRANCH,RAJKOT

**For, JIGNESH ELECTRIC STORES**  
For, Jignesh Electric Stores  
Manager Partner  
Authorised Signatory

**TERMS & CONDITIONS:**  
1. GOODS ONCE SOLD WILL NOT BE TAKEN BACK.  
2. SUBJECT TO RAJKOT JURISDICTION. E.& O.E.

**Registrar  
Atmiya University  
Rajkot**







**ATMIYA  
UNIVERSITY**

**NAAC – Cycle – 1  
AISHE: U-0967**

**Criterion- VII**

**IV&BP**

**KI 7.2**

**M 7.2.1**

**PUJARA ELECTRICALS**

SANGANWA CHOWK RAJDEV STREET RAJKOT  
Phone: 0281 2243149 Email: 99041 00075

**DEBIT INVOICE ORIGINAL**

**To, ATMIYA UNIVERSITY FACULTY OF ENGINEERING AND TECHNOLOGY**

KALAWAD ROAD,  
RAJKOT (Gujarat)  
Ph. No:

Party's GST No:

Invoice No: **GT 59** Date: 09/09/2020

Challan No. : 4619 Date : 07/09/20  
Transport :  
L.R.No. : Date : / /  
Vehicle No. : No. of Case :

**Payment must be made within days.**

Sr.	Description	HSN	Rate	Tax %	Amount	CGST	SGST	Total
1	HAVELLS 18" PEDSTAL V3	8414	4.00	15.25%	4340.00	18.00		14712.60
					<b>4.00</b>	<b>Sub Total</b>		<b>14,712.60</b>

**PAID**

Ch. No. **000196**  
Bank: **140 FC**  
Date: **23-9-2020**

<b>HAVELLS TOLL FREE NO 1800 103 1313</b>	P.O NO. AUFobc/Fan/PO/09-2020-21 Dated: 04-09-20	<b>Sub Total</b>	<b>14,712.60</b>
<b>USHA TOLL FREE NO 1800 1033 111</b>		ROUND OFF	-1.00
<b>CROMPTON TOLL FREE NO 1800 419 0505</b>		SGST	1,324.04
		CGST	1,324.04
		Round Off	0.32
		<b>Grand Total</b>	<b>17,360.00</b>

GST Summary	Taxable Amnt	SGST	SGST AMT	CGST	CGST AMT	Total GST
GST @18.00	14712.60	9.00	1324.13	9.00	1324.13	2648.26
<b>Total :</b>	<b>14712.60</b>		<b>1324.13</b>		<b>1324.13</b>	<b>2648.26</b>

**Rs. Seventeen thousand three hundred sixty only.**

**GST No: 24AQGPP3466M1ZE**

Bank Details: **HDFC BANK LTD**  
A/C No: 50200018708823 IFSC CODE: HDFC0000101  
BRANCH: Dr YAGNIK ROAD BRANCH, RAJKOT.

**For, PUJARA ELECTRICALS**  
**FOR PUJARA ELECTRICALS**  
Alpa.M. Pujari  
PROPRIETOR/MANAGER  
Authorised Signatory

**TERMS & CONDITIONS:**  
1. GOODS ONCE SOLD WILL NOT BE TAKEN BACK.  
2. SUBJECT TO RAJKOT JURISDICTION, E.& O.E.

**Registrar  
Atmiya University  
Rajkot**





**ATMIYA  
UNIVERSITY**

**NAAC – Cycle – 1  
AISHE: U-0967**

**Criterion- VII**

**IV&BP**

**KI 7.2**

**M 7.2.1**

**PUJARA ELECTRICALS**

SANGANWA CHOWK RAJDEV STREET RAJKOT  
Phone: 0281 2243149 Email: 99041 00075

**DEBIT INVOICE ORIGINAL**

**To, ATMIYA UNIVERSITY FACULTY**  
OF BUSINESS AND COMMERCE  
KALAWAD ROAD  
**RAJKOT (Gujarat)**  
Ph. No:

Invoice No: **ET 53** Date: **02/09/2020**  
Challan No. : 4618 Date :02/09/20  
Transport ORDER BY VIKASBHAI  
L.R.No. : Date : / /  
Vehicle No. : No.of Case :

Party's GST No: **Payment must be made within days.**

Sl	Description	HSN	Qty	Rate	Amount	Tax	Total
1	HAVELS 18" PEDSTAL V3	8414	3.00	15.25%	4340.00	18.00	11034.45
					<b>3.00</b>	<b>Sub Total</b>	<b>11,034.45</b>

**PAID**

Ch. No. **000189**  
Bank **HDFC**  
Date **23-9-2020**

HAVELS TOLL FREE NO 1800 103 1313  
USHA TOLL FREE NO 1800 1033 111  
CROMPTON TOLL FREE NO 1800 419 0505

AU Foet/Fan/PO/10-2020-21  
Dated:-04/09/2020

<b>Sub Total</b>	<b>11,034.45</b>
ROUND OFF	-0.50
SGST	993.06
CGST	993.06
Round Off	-0.07
<b>Total</b>	<b>13,020.00</b>

GST Summary	Taxable Amnt	SGST	SGST AMT	CGST	CGST AMT	Total GST
GST @18.00	11033.95	9.00	993.06	9.00	993.06	1986.12
<b>Total :</b>	<b>11033.95</b>		<b>993.06</b>		<b>993.06</b>	<b>1986.12</b>

**Rs. Thirteen thousand twenty only.**

GST No: 24AQGPP3466M1ZE  
Bank Details: **HDFC BANK LTD**  
A/C No: 50200018708823 IFSC CODE: HDFC0000101  
BRANCH: Dr YAGNIK ROAD BRANCH, RAJKOT.

**For, PUJARA ELECTRICALS**  
FOR PUJARA ELECTRICALS  
*A.P.A.M. Pujara*  
PROPRIETOR / MANAGER  
Authorised Signatory

**TERMS & CONDITIONS:**  
1. GOODS ONCE SOLD WILL NOT BE TAKEN BACK.  
2. SUBJECT TO RAJKOT JURISDICTION. E.& O.E.

*[Signature]*

**Registrar  
Atmiya University  
Rajkot**





**ATMIYA UNIVERSITY**

**NAAC – Cycle – 1  
AISHE: U-0967**

**Criterion- VII**

**IV&BP**

**KI 7.2**

**M 7.2.1**

**PUJARA ELECTRICALS**

SANGANWA CHOWK RAJDEV STREET RAJKOT  
Phone: 0281 2243149 Email: 99041 00075

**ORIGINAL**

**DEBIT INVOICE**

**To, ATMIYA UNIVERSITY FACULTY OF ENGINEERING AND TECHNOLOGY**  
KALAWAD ROAD, RAJKOT (Gujarat)  
Ph. No:

Invoice No: 6125 Date: 09/07/2020  
Challan No. : 4611 Date : 10/07/20  
Transport :  
L.R.No. : Date : / /  
Vehicle No. : No. of Case :

Party's GST No: **Payment must be made within days.**

Sr	Particulars	HSN	Quantity	Rate	Rate	GST%	Amount
1	HAVELLS 16" WALL FAN SWING	8414	2.00	15.25%	1975.00	18.00	3347.63
<b>Sub Total</b>							<b>3,347.63</b>

**PAID**

Ch No. 413981

Date: 18-7-2020

GST Summary	Taxable Amnt	SGST	SGST AMT	CGST	CGST AMT	Total GST
GST @18.00	3347.63	9.00	301.29	9.00	301.29	602.58
<b>Total :</b>	<b>3347.63</b>		<b>301.29</b>		<b>301.29</b>	<b>602.58</b>

**Sub Total 3,347.63**  
SGST 301.29  
CGST 301.29  
Round Off -0.21  
**Grand Total 3,950.00**

**RS. Three thousand nine hundred fifty only.**

GST No: 24AQGPP3466M1ZE  
Bank Details: **HDFC BANK LTD**  
A/C No: 59200018708823 IFSC CODE: HDFC0000101  
BRANCH: Dr. YAGNIK ROAD BRANCH, RAJKOT.

**For, PUJARA ELECTRICALS**  
FOR PUJARA ELECTRICALS  
APPROVED BY: \_\_\_\_\_ PROPRIETOR/MANAGER.  
E. & O.E. Authorised Signatory

**TERMS & CONDITIONS:**  
1. GOODS ONCE SOLD WILL NOT BE TAKEN BACK.  
2. SUBJECT TO RAJKOT JURISDICTION.

**Registrar  
Atmiya University  
Rajkot**







**ATMIYA  
UNIVERSITY**

**NAAC – Cycle – 1  
AISHE: U-0967**

**Criterion- VII**

**IV&BP**

**KI 7.2**

**M 7.2.1**

PAID

## PUJARA ELECTRICALS

SANGANWA CHOWK RAJDEV STREET RAJKOT  
Phone: 0281 2243149 Email: 99041 00075

**ORIGINAL**

**DEBIT INVOICE**

**To, ATMIYA UNIVERSITY FOPS**  
YOGIDHAM GURUKUL  
KALAWAD ROAD  
**RAJKOT (Gujarat)**  
Ph. No:  
Party's GST No:

Invoice No: 63 12 Date: 17/06/2020  
Challan No. : 4605 Date :17/06/20  
Transport :  
L.R.No. : Date : / /  
Vehicle No. : No.of Case :

**Payment must be made within days.**

Sr	Particulars	HSN	Quantity	Disc	Rate	GST%	Amount	
1	HAVELS 12" EX FAN METAL DB	8414	3.00	15.25%	1920.00	18.00	4881.60	
2	HAVELS 12" EX FAN METAL DSP	8414	9.00	15.25%	1350.00	18.00	10297.13	
<b>12.00</b>							<b>Sub Total</b>	<b>15,178.73</b>

**PAID**  
413986  
Bank: Axis  
Date: 18-7-2020

<b>HAVELLS TOLL FREE NO 1800 103 1313</b> <b>USHA TOLL FREE NO 1800 1033 111</b> <b>CROMPTON TOLL FREE NO 1800 419 0505</b>		ORDER ON WHATSAPP BY VIKASH PATHAK DATE 16/06/20 TIME 9:58 AM	<b>Sub Total</b> 15,178.73 ROUND OFF -1.00 SGST 1,366.00 CGST 1,366.00 Round Off 0.27 <b>Grand Total</b> 17,910.00
<b>GST Summary</b> Taxable Amnt 15177.73 GST @18.00 2732.00 <b>Total</b> 15177.73	SGST 1366.00 CGST 1366.00 <b>Total GST</b> 2732.00	<b>Total</b> 15177.73 <b>1366.00</b> <b>1366.00</b> <b>2732.00</b>	

**Rs. Seventeen thousand nine hundred ten only.**

GST No:24AQGPP3466M1ZE  
 Bank Details: **HDFC BANK LTD**  
 A/C.No.: 50200018708823 IFSC CODE: HDFC0000101  
 BRANCH: DRYAGNIK ROAD BRANCH, RAJKOT.

**For, PUJARA ELECTRICALS**  
 FOR PUJARA ELECTRICAL  
 PROPRIETOR/MANAGE  
 Authorised Signatory

**TERMS & CONDITIONS:**  
 1. GOODS ONCE SOLD WILL NOT BE TAKEN BACK.  
 2. SUBJECT TO RAJKOT JURISDICTION. E.& O.E.

*[Handwritten Signature]*

**Registrar  
Atmiya University  
Rajkot**





**ATMIYA  
UNIVERSITY**

**NAAC – Cycle – 1  
AISHE: U-0967**

**Criterion- VII**

**IV&BP**

**KI 7.2**

**M 7.2.1**

PUJARA ELECTRICALS						
SANGANWA CHOWK RAJDEV STREET RAJKOT Phone: 0281 2243149 Email: 99041 00075						
<b>DEBIT INVOICE ORIGINAL</b>						
<b>To, ATMIYA UNIVERSITY FACULTY</b> OF BUSINESS & COMMERCE KALAWAD ROAD  <b>RAJKOT (Gujarat)</b> Ph. No: Party's GST No:				Invoice No: <b>GT 5</b> Date: <b>28/05/2020</b> Challan No. : 4603 Date : / / Transport KIRITSHAT AUTO L.R.No. : Date : / / Vehicle No. : No.of Case :		
				<b>Payment must be made within days.</b>		
Sr	Particulars	SN/Code	QTY/Entry	Rate	GST%	Amount
1	HAVELLS 18" PEDASTAL V3	8414	5.00	3678.15	18.00	18390.75
				<b>5.00</b>	<b>Sub Total</b>	<b>18,390.75</b>
<b>HAVELLS TOLL FREE NO 1800 103 1313</b> <b>USHA TOLL FREE NO 1800 1033 111</b> <b>CROMPTON TOLL FREE NO 1800 419 0505</b>				<b>Sub Total 18,390.75</b> <b>SGST 1,655.17</b> <b>CGST 1,655.17</b>		
<b>GST Summary</b>	<b>Taxable Amnt</b>	<b>SGST</b>	<b>SGST AMT</b>	<b>CGST</b>	<b>CGST AMT</b>	<b>Total GST</b>
GST @18.00	18390.75	9.00	1655.17	9.00	1655.17	3310.34
<b>Total :</b>	<b>18390.75</b>		<b>1655.17</b>		<b>1655.17</b>	<b>3310.34</b>
<b>Rs. Twenty one thousand seven hundred one only.</b>				<b>Sub Total 18,390.75</b>		
<b>GST No:24AQGPP3466M1ZE</b> <b>Bank Details: HDFC BANK LTD</b> A/C No: 50200018708823 IFSC CODE: HDFC0000101 BRANCH: Dr YAGNIK ROAD BRANCH, RAJKOT.				<b>For, PUJARA ELECTRICALS</b> FOR, PUJARA ELECTRICALS  <b>PROPRIETOR/MANAGER</b> Authorised Signatory		
<b>TERMS &amp; CONDITIONS:</b> 1. GOODS ONCE SOLD WILL NOT BE TAKEN BACK. 2. SUBJECT TO RAJKOT JURISDICTION. E.&O.E.						

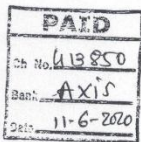

**Registrar  
Atmiya University  
Rajkot**





**ATMIYA  
UNIVERSITY**

**NAAC – Cycle – 1  
AISHE: U-0967**

**Criterion- VII**

**IV&BP**

**KI 7.2**

**M 7.2.1**

**CHANDAN Electric Service**  
Since 1988

"Sneh Ashish", 20 New Jagnath  
Rajkot - 360001 P:0281-2467801  
E:chandaneleservice@yahoo.com  
M:+91 990 990 5526, +91 942 950 1677

Debit Memo		Tax Invoice				Original				
To, Atmiya University Rajkot 24-Gujarat Mobile No : 9874563210					Has Reverse Charges : No Invoice No. : R-646 Invoice Dt. : 01-01-2021 Outstanding Balance: <b>2,016.00</b> Payment Should be make in 15 days.					
Sr	HSN	Particular	Qty	Rate	Disc %	Taxable Amount	CGST %	CGST Tax	SGST %	SGST Tax
1	9405	Order No: SC12-354 Date: 28/12/2020 BN 12W Round Cylinder Led Cob Light <u>Panel Light Led</u>	3 pc	600.00		1,800.00	6.0	108.00	6.0	108.00
Bank : HDFC BANK Branch : Dr. Yagnik Road RTGS/IFSC : HDFC0000101 A/C : 50200040487961 Amount in Words: Two Thousand Sixteen Only GSTIN No : 24ABJPC0071B1ZJ						Amount 1,800.00 SGST 108.00 CGST 108.00				
						<b>Grand Total</b> ₹ <b>2,016.00</b>				
<b>Terms &amp; Conditions:</b> 1. Interest 18% p.a. will be charged, if payment not made as per order's terms. 2. Goods once sold will not be taken back. 3. Guarantee & Warrantee are according to the manufacturer's terms and conditions. 4. All Trasactions are subject to Rajkot jurisdiction. 5. E & OE.						<b>For, Chandan Electric Service</b> FO <i>[Signature]</i> Authorised Signatory				

PAID  
000866  
HDFC  
13-02-2021

We deal in the most trusted names in the electrical field.

HAVELLS | Crabtree | GreatWhite | LARSEN & TOUBRO | norisy | SM | ADLER | DIGITECH | RR | V-GUARD

*[Signature]*

**Registrar  
Atmiya University  
Rajkot**







**ATMIYA  
UNIVERSITY**

**NAAC – Cycle – 1  
AISHE: U-0967**

**Criterion- VII**

**IV&BP**

**KI 7.2**

**M 7.2.1**

**REVA ELECTRICALS**

SANGANWA CHOWK RAJDEV STREET RAJKOT  
Phone: 2234278 2228916 99041 00075 Email: 93693 93694

**DEBIT INVOICE ORIGINAL**

**To, ATMIYA UNIVERSITY**  
YOGIDHAM GURUKUL  
KALAWAD ROAD  
**RAJKOT (Gujarat)**  
Ph. No: \_\_\_\_\_  
Party's GST No: \_\_\_\_\_

Invoice No: GT 2101 Date: 31/01/2020  
Challan No. : 16565 Date : 31/01/20  
Transport : \_\_\_\_\_  
L.R.No. : \_\_\_\_\_ Date : / /  
Vehicle No. : \_\_\_\_\_ No. of Case : \_\_\_\_\_

**Payment must be made within days.**

Sl	Particulars	Qty	Rate	Disc	Net	ES	Amount
1	SSK SURFACE SDS 15W <i>Panel Light Lead</i>	94051090	7.00	10.715	670.00	12.00	4187.47
					<b>7.00</b>	<b>Sub Total</b>	<b>4,187.47</b>

**PAID**

Ch. No. *423899*

Bank *Axis*

Date *12-2-20*

HAVELLS TOLL FREE NO 1800 103 1313 USHA TOLL FREE NO 1800 1033 111 CROMPTON TOLL FREE NO 1800 419 0505						Sub Total <b>4,187.47</b>
GST Summary	Taxable Amnt	SGST	SGST AMT	CGST	CGST AMT	Total GST
GST @12.00	4187.47	6.00	251.25	6.00	251.25	502.50
<b>Total :</b>	<b>4187.47</b>		<b>251.25</b>		<b>251.25</b>	<b>502.50</b>
						Round Off <b>0.03</b>
						<b>Stand Total</b> <b>4,690.00</b>

**Rs. Four thousand six hundred ninety only.**

GST No: 24ACYPP0074B1ZM  
Bank Details: **HDFC BANK LTD,**  
A/C No: 50200013922771 IFSC CODE: HDFC0000101  
BRANCH: Dr YAGNIK ROAD BRANCH, RAJKOT

**For, REVA ELECTRICALS**  
Reva Electricals  
*[Signature]*  
Proprietor  
Authorised Signatory

**TERMS & CONDITIONS:**  
1. GOODS ONCE SOLD WILL NOT BE TAKEN BACK.  
2. SUBJECT TO RAJKOT JURISDICTION. E.& O.E.

*[Signature]*

**Registrar  
Atmiya University  
Rajkot**





**OUTCOME & IMPACT**

**Patent for SMART LIGHTING SYSTEM FOR ENERGY CONSERVATION**

(12) PATENT APPLICATION PUBLICATION

(21) Application No.202421045036 A

(19) INDIA

(22) Date of filing of Application :11/06/2024

(43) Publication Date : 19/07/2024

(54) Title of the invention : SMART LIGHTING SYSTEMS FOR ENERGY CONSERVATION

(51) International classification :I05B0047110000, F21V0023040000, F04N0005330000, F05B0047100000, F21S0002000000

(86) International Application No :NA  
Filing Date :NA

(87) International Publication No :NA

(61) Patent of Addition to Application Number :NA  
Filing Date :NA

(62) Divisional to Application Number :NA  
Filing Date :NA

(71)Name of Applicant :

1)Atmiya University  
Address of Applicant :Atmiya University, "Yogidham Gurukul", Kalawad Road, Rajkot – 360005, Gujarat, India Rajkot -----

2)Dr. Ashish M. Kotbari

Name of Applicant : NA

Address of Applicant : NA

(72)Name of Inventor :

1)Dr. Ashish M. Kotbari

Address of Applicant :Director-Research, Innovation & Translation, Atmiya University, "Yogidham Gurukul", Kalawad Road, Rajkot – 360005 Rajkot -----

(57) Abstract :

Abstract Smart Lighting Systems for Energy Conservation The present invention provides a smart lighting system designed to conserve energy by automatically adjusting illumination based on ambient light conditions and human occupancy. The system includes a Light Dependent Resistor (L) sensor to monitor ambient light levels and a Passive Infrared (P) sensor to detect human motion. An Arduino UNO microcontroller (M) processes the input from these sensors to control a switching module (SM), which activates the lighting only when necessary. The system allows for customizable settings, enabling users to adjust the ambient light threshold and the duration for which the lights remain on after motion detection. This smart lighting system significantly reduces energy wastage, lowers electricity bills, and contributes to environmental sustainability. It is versatile and applicable in various indoor and outdoor environments, such as staircases, parking areas, building lobbies, halls, porches, decks, and backyards. Figure 1

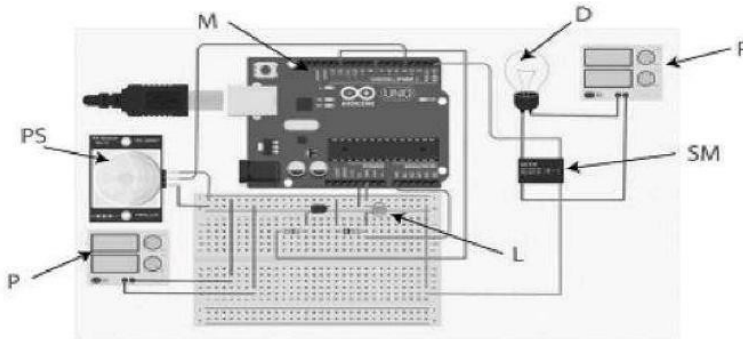

Figure 1 shows diagram of smart lighting system

No. of Pages : 16 No. of Claims : 7

The Patent Office Journal No. 29/2024 Dated: 19/07/2024

**Registrar  
Atmiya University  
Rajkot**

62795





**Impact of Good Power Factor**

Power factor is the measure of how effectively the incoming power is used in an electrical system. A high power factor indicates that the power supplied to the electrical system is effectively used. By using Automatic Power Factor Correction (APFC) panels, at Atmiya University power factor is maintained closer to unity. Impact of maintaining such high power factors are as follows:

1. Less current is drawn from the utility company *i.e.* Paschim Gujarat Vij Company Limited (PGVCL), therefore less electricity bills.
2. With less current drawn, equipment operates at lower temperatures, reducing thermal stress and extending the lifespan of electrical equipment.
3. Reduction in maximum demand tariff and thereby reduction in the electricity bills.
4. Utility company may charge customers a penalty when power factor is less than a determined value. Such type of penalty is never imposed to Atmiya University by PGVCL.
5. High power factor reduces the stress on electrical equipment, minimizing the risk of equipment failures and the associated repair or replacement expenses. This translates into long-term cost savings and improved operational efficiency of the electrical infrastructure.
6. Less power needs to be generated by the utility company to meet the demand of Atmiya University, leading to reduced fossil fuel consumption and emissions. In this way, by maintaining high power factor, Atmiya University is indirectly contributing in reduction of Green House Gases (GHGs) emission and carbon footprint.

**Seema Vachhani**  
Certified Energy Auditor  
Reg. No. EA-25555  
Bureau of Energy Efficiency, India.

**Registrar**  
**Atmiya University**  
**Rajkot**







**Recorded Power Factor**

Academic Year	Billing Month	Recorded PF
2019-20	Apr-19	0.996
	May-19	0.997
	Jun-19	0.998
	Jul-19	0.993
	Aug-19	0.994
	Sep-19	0.995
	Oct-19	0.993
	Nov-19	0.996
	Dec-19	0.999
	Jan-20	0.996
	Feb-20	0.998
	Mar-20	0.999
	<b>Avg.</b>	<b>0.9961</b>

Academic Year	Billing Month	Recorded PF
2020-21	Apr-20	0.995
	May-20	0.996
	Jun-20	0.998
	Jul-20	0.999
	Aug-20	0.998
	Sep-20	0.999
	Oct-20	0.998
	Nov-20	0.995
	Dec-20	0.989
	Jan-21	0.997
	Feb-21	0.997
	Mar-21	0.998
	<b>Avg.</b>	<b>0.9965</b>

Academic Year	Billing Month	Recorded PF
2021-22	Apr-21	0.999
	May-21	0.999
	Jun-21	0.999
	Jul-21	0.999
	Aug-21	0.999
	Sep-21	0.999
	Oct-21	0.999
	Nov-21	1
	Dec-21	0.994
	Jan-22	0.995
	Feb-22	0.867
	Mar-22	0.957
	<b>Avg.</b>	<b>0.984</b>

Academic Year	Billing Month	Recorded PF
2022-23	Apr-22	0.978
	May-22	0.984
	Jun-22	0.988
	Jul-22	0.996
	Aug-22	0.986
	Sep-22	0.997
	Oct-22	0.996
	Nov-22	0.996
	Dec-22	0.996
	Jan-23	0.997
	Feb-23	0.996
	Mar-23	0.996
	<b>Avg.</b>	<b>0.992</b>

**Registrar  
Atmiya University  
Rajkot**





**ATMIYA  
UNIVERSITY**

**NAAC – Cycle – 1  
AISHE: U-0967**

**Criterion- VII**

**IV&BP**

**KI 7.2**

**M 7.2.1**



**ATMIYA UNIVERSITY**

(Established under the Gujarat Private University Act 11, 2018)

Yogidham Gurukul, Kalawad Road, Rajkot - 360005, Gujarat (INDIA)

Academic Year	Billing Month	Recorded PF
2023-24	Apr-23	0.992
	May-23	0.984
	Jun-23	0.988
	Jul-23	0.99
	Aug-23	0.989
	Sep-23	0.972
	Oct-23	0.994
	Nov-23	0.974
	Dec-23	0.998
	Jan-24	0.974
	Feb-24	0.97
	Mar-24	0.986
	Avg.	0.984

*Seema Vachhani*  
05.11.24  
**Seema Vachhani**  
Certified Energy Auditor  
Reg. No. : EA-25555  
Bureau of Energy Efficiency, India  
Energy Audit Cell  
Atmiya University

*[Signature]*  
Registrar  
Atmiya University  
**Registrar**  
Atmiya University  
Rajkot

Page 2 of 2

*[Signature]*  
**Registrar**  
Atmiya University  
Rajkot





### Power Consumption Comparison

Particular	LED Light without Sensor	LED Light with Motion Sensor	Inhouse Invented, Developed & Installed LED Bulb
Power Consumption per Lightibg Fixture (kWh)	$18 \times 12 \times 300 / 1000 = 64.8$	$18 \times (600 \times 30 / 3600) \times 300 / 1000 = 27$	$18 \times (200 \times 30 / 3600) \times 300 / 1000 = 9$
Power Consumption by 100 Lightibg Fixtures (kWh)	6,480	2,700	900
Cost of Power Consumption of 100 Lighting Fixtures (INR)	27,216	11,340	3,780
Carbon Emission (KgCO <sub>2</sub> e)	4,620	1,925	642

#### Assumptions:

1. No. of working days are 300 in a year, approximately.
2. Lighting fixtures are in ON state for 12 hours averagely in a day.
4. 600 movements are detected averagely in a working day.
3. Sensor based bulbs remain consume power for 30 seconds, when motion detected.
4. All lighting fixture are of 18 W power rating.

Prepared By:

**Seema Vachhani**  
Certified Energy Auditor  
Reg. No. EA-25555  
Bureau of Energy Efficiency, India.

Atmiya University

**Registrar**  
**Atmiya University**  
**Rajkot**







**Awards for Sustainable Practices**



**Registrar  
Atmiya University  
Rajkot**







**Registrar  
Atmiya University  
Rajkot**





**ATMIYA  
UNIVERSITY**

**NAAC – Cycle – 1  
AISHE: U-0967**

**Criterion- VII**

**IV&BP**

**KI 7.2**

**M 7.2.1**



**Registrar  
Atmiya University  
Rajkot**







**Registrar  
Atmiya University  
Rajkot**

